

SuperMax^{BY LAGUNA}
OWNERS'S MANUAL

SuperBrush 24 & 36



LAGUNA

SUPMX-91267
SUPMX-91367

LAGUNATOOLS.com

2 SUPERBRUSH OWNER'S MANUAL

CONGRATULATIONS:

Thank you for investing in a Super Brush sander. This sander is one of a family of unique machines proudly offered by Laguna Tools. Every Laguna machine is engineered for years of dependable service. Please feel free to contact Laguna Tools if you have a question or suggestion. We appreciate working with you and your choice of a Laguna Tools machine for your shop.

Regards, Torben Helshoj

President & Founder Laguna Tools

MODEL IDENTIFICATION:

Your SuperBrush sander is one of a family of machines from Laguna Tools designed to help you achieve results comparable to industrial-size sanders at a fraction of the cost. For future reference, find the model, stock and serial numbers on the back of the machine base and write them below.

Model: _____

Date Purchased: _____

Stock Number: _____

Distributor: _____

Serial Number: _____

IMPORTANT KEEP THIS MANUAL HANDY:

Please read this manual first. It was designed to help you get the most from your SuperBrush sander. Before unpacking or using the machine, familiarize yourself with its components, features, and basic adjustments by reviewing the following pages. You will find it an invaluable aid in setting up, operating, and servicing your machine. If, after reviewing this manual, you still have a problem you can't solve, please call your distributor.

LATEST MANUAL:

Below is a QR code which will direct you to the manual reference page, where the latest version of the SuperBrush manual is located on the Laguna Tools website. The online manual may have updates and information added after the printed copy was released. Scan the code with your smartphone or copy the URL link to be directed to the latest manual page to reference your specific machine and model.

<https://lagunatools.com/resources/product-manuals/#classic>



LAGUNATOOLS.COM

CONTENTS

ABOUT THE SUPERBRUSH SYSTEM

SUPERBRUSH Nomenclature.....4
 Unpacking Your SUPERBRUSH Sander5

SETTING UP YOUR SUPERBRUSH

Making Electrical Connections6
 Connecting Dust Collectors7
 Checking For Machine Level.....7
 Checking Brush Alignment..... 7
 Checking Table Height Controls7
 Brush Speed Adjustment 8
 Checking Conveyor Belt 8

OPERATING YOUR SUPERBRUSH

Basic Operating Procedures.....9
 Adjusting Tension Rollers 9
 SUPERBRUSH Operating Controls9
 Setting Depth of Cut10
 Selecting Stock Feed Rates..... 10
 Using The Depth Gauge..... 11
 Monthly Maintenance 11

TIPS FOR MAXIMUM

PERFORMANCE 12

TROUBLESHOOTING YOUR SUPERBRUSH

Troubleshooting Guide: Motors..... 13
 Troubleshooting Guide: Conveyor14
 Troubleshooting Guide: Machine.....15

SERVICING YOUR SUPERBRUSH

Adjusting Height Controls.....16
 Adjusting Table Support Castings16
 Adjusting Brush Head..... 16
 Leveling Table..... 18
 Miter Gear Alignment..... 18
 Brush Speed Adjustment19
 Replacing Brush20 & 23
 Replacing Conveyor Belts.....20
 Replacing V-Belt.....21
 Rotating/Replacing Bearings..... 22
 Replacing Electrical Components 24
 Electrical Diagrams.....25 & 26

SUPERBRUSH TECHNICAL DATA

SUPERBRUSH Specifications27
 Parts List For Stand 28
 Parts List For Brush Assembly 30
 Parts List For Conveyor Assembly32
 SUPERBRUSH Accessories & Supplies 35

FOR YOUR SAFETY: Read all instructions carefully, and note the safety cautions on the opposite page and on the back cover of this manual.

ABOUT THE SUPERBRUSH SYSTEM

This manual is designed to help familiarize you with your SUPERBRUSH sander, and to help you take advantage of its exclusive features. By understanding its major components, and how they work together, you will be able to get the most from your investment. The SUPERBRUSH system is basically made up of: 1) a height adjustment handle

which raises and lowers the conveyor table; 2) a brush speed control handle which controls brush speed from 400 to 1200 RPM; 3) a motor starter switch which starts and stops the drive motor and sanding brush; and 4) a feed rate control knob which starts feed conveyor and selects feed rate from 0-15 feet per minute.

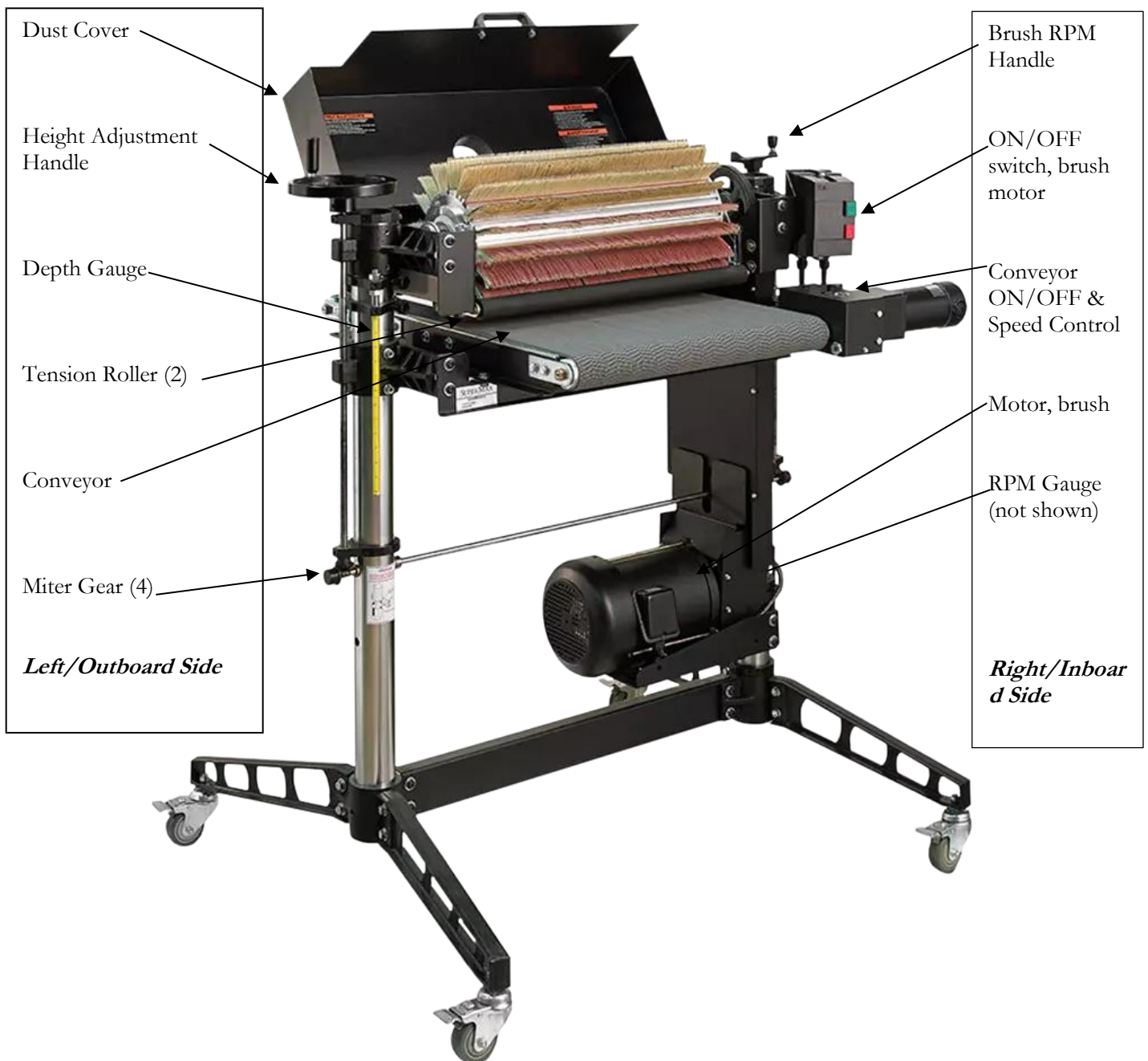

Fig. 1. SUPERBRUSH nomenclature, 24" shown with accessories.

UNPACKING The Sander

The sander has been shipped mostly assembled from the factory in a cardboard shroud on a pallet. If any damage has occurred as a result of shipment, notify the transportation company as soon as possible and ask them to make an immediate inspection. Ask for a damage or loss report. Also notify your dealer of any loss or damage during shipment. See Warranty Statement.

Important: To avoid problems and potential damage to the machine, please read through the unpacking instructions below before proceeding to set up the machine in your shop.

1. Unbolt the machine legs from the shipping pallet. Install the leveling feet or optional casters on legs (Fig. 2 & 2A) with a washer(s) and nut(s). Tighten with a 9/16" or 3/4" wrench. The Leveling Feet and mounting hardware are packaged with the machine.

2. Loosen the hex nut and set screws on the table support castings (Fig. 3). The set screws on the table support castings have been tightened at the factory to eliminate free-play between the table support casting and the column tube during shipment. There are two table support castings, one each for the right and left column tubes. **Important:** These set screws are tightened for shipping and must be loosened and readjusted before operating either the height adjustment mechanism or the conveyor drive.

To properly adjust for operation, loosen each set screw by first loosening its hex nut with an open-end wrench and then the set screw with an Allen wrench. Then retighten each set screw with your fingers so it only lightly touches the column tube. Hold each set screw in position with an Allen wrench and retighten the hex nut. Failure to follow these procedures may result in misalignment of the drum(s) and/or the conveyor table.

Caution: Do not loosen the set screws on the upper support castings.

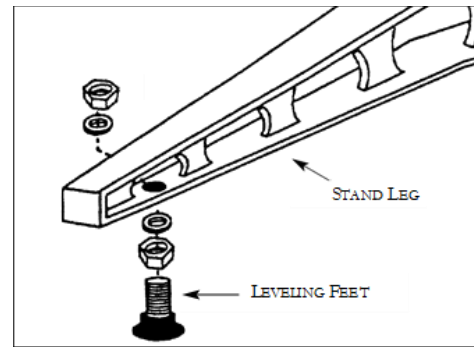

Fig. 2A. Leveling Feet and mounting hardware.



Fig. 2. Caster and mounting hardware.

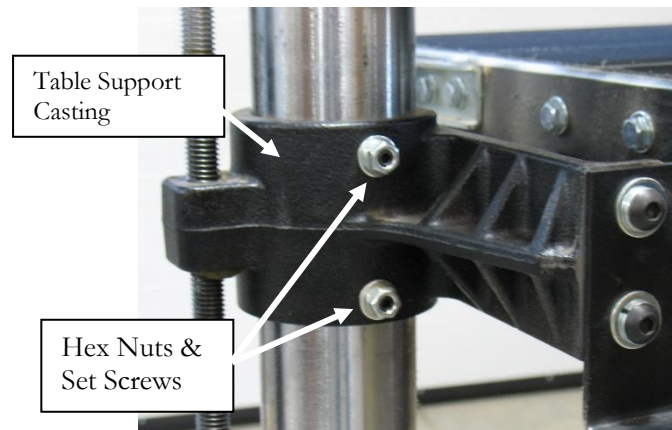

Fig. 3. Table support casting and set screws.

SETTING UP

Your SUPERBRUSH sander was adjusted and aligned at the factory, and it has been carefully packed for shipment. However, because of possible stress during transit, the unit should be thoroughly checked before use. This section covers the pre-operational checks you should make after unpacking and final assembly. Unnecessary problems can be avoided if these essential checks are performed before operating. Likewise, performing the recommended monthly maintenance procedures will help assure trouble-free service.

MAKING ELECTRICAL CONNECTIONS

Power for the brush of your SUPERBRUSH is supplied by a 5HP, 208-230 volt single-phase, motor. A 30 amp (min.) circuit/breaker is required.

A power cord and plug are NOT included, and need to be sourced locally (not available from Laguna Tools). They should be installed by a qualified technician. Two hot (load) wires and one green (ground) wire. These wires are connected into the junction box at the bottom of the conveyor motor housing.



Fig. 4.

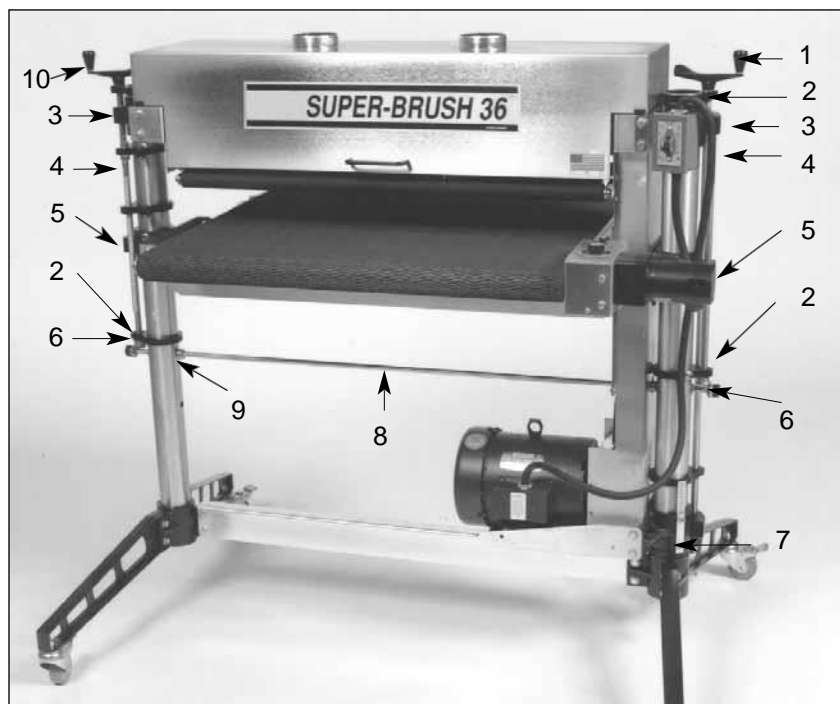

Fig. 5. SUPERBRUSH Components.

1. Brush Speed Handle.
2. Adjusting Screw Support.
3. Brush Support Casting.
4. Height Adjusting Screw.
5. Table Support Casting.
6. Miter Gear.
7. Motor Support Casting.
8. Transfer Rod.
9. Shaft Collars.
10. Height Adjustment Handle.

CONNECTING DUST COLLECTORS

Dust collection is necessary for all SUPERBRUSH models. The SUPERBRUSH 24 is equipped with two 4" diameter dust exhaust ports at the top of the brush cover. The SUPERBRUSH 36 has three 4" dust exhaust ports.

To attach the SUPERBRUSH to your collection system, install 4" hose from your collector. (See Tips For Maximum Performance) The minimum recommended dust collector capacities at the dust port(s) are: SUPERBRUSH 24: 600 CFM; SUPERBRUSH 36: 1,200 CFM. For best results, follow the recommendations of the manufacturer of your dust collection equipment. NOTE: Some applications will require more dust collection than the recommended minimum CFM.

CHECKING MACHINE FOR LEVEL

Proper leveling of the machine is essential to achieve continued maximum performance from the SUPERBRUSH. Before making fine adjustments, place the unit where it will be used in the shop. Then adjust the four leveling feet using a carpenter's level both across the machine and in line with the machine, placing the level on the conveyor bed. If you have equipped your SUPERBRUSH with the optional caster set, do the same after positioning the machine where it will be operated most often. Mark the position of the legs on the floor with tape so it can be returned to the same position.

HEIGHT ADJUSTMENT

The table height is controlled by the height adjustment handle (10)(Fig.5). Turning the handle raises or lowers both sides of the table simultaneously by transferring the handle rotation through the miter gear and transfer rod assembly. One revolution of the handle raises or lowers the table 3/32 of an inch.

Before operating height adjustment, be sure both set screws located in both table support castings (Fig. 3) are loose to allow table support to slide on both column tubes. (These set screws are tightened for shipping.)



Fig. 6. Checking brush alignment and table height adjustment (outboard side).

BRUSH ALIGNMENT

The brush must be parallel to the conveyor bed surface. Brush alignment can be visually checked by raising the tension rollers (Fig. 6) to their highest position (See Tension Roller Adjustment page 9) and raising the table so that the brush just contacts the conveyor surface. Brush contact should be

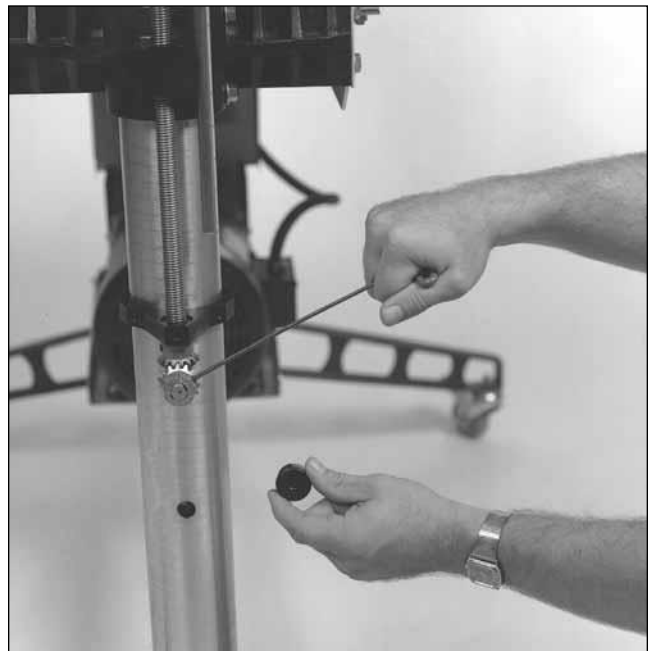

Fig. 7. Adjusting brush alignment.

equal across the width of the conveyor. If the SUPERBRUSH is properly leveled (See checking machine for level), brush misalignment can be corrected by loosening the two set screws at the front of the outboard brush support casting (Fig. 5) and by raising or lowering casting to correct alignment.

NOTE: Improper brush alignment will cause uneven results and lead to reduced brush life.

BRUSH (RPM) SPEED ADJUSTMENT

The SUPERBRUSH is equipped with a variable speed drive which allows the brush to be operated anywhere between 400 and 1200 RPM. The faster the brush speed, the more aggressive the brush action. The brush speed control handle (1)(Fig. 5) raises or lowers the motor support casting (7)(Fig. 5) which activates the variable speed drive pulley.

RPM GAUGE

The RPM gauge (Fig. 8) displays the brush speed and is read where the scale intersects the top of the screw support casting. To calibrate the gauge, lower the motor to the lowest position. Loosen both hex nuts while holding set screws. Position the RPM scale so that "400" RPM intersects the top of the screw support casting (Fig. 8). Tighten hex nuts to hold gauge in this position.



Fig. 8. Brush RPM gauge.

CHECKING THE CONVEYOR BELT

Conveyor belt tracking adjustments may occasionally be necessary during break-in and normal operation to compensate for belt stretching. If adjustments are necessary, follow the instructions below:

Belt tracking adjustments are made while the conveyor belt is running. With the conveyor unit on and set at the fastest speed setting, watch for a tendency of the conveyor belt to drift to one side of the conveyor. To adjust the belt tracking, tighten the take-up screw nut (see Fig. 9) on the side the belt is drifting toward, and loosen the take-up screw nut on the opposite side. Adjusting the take-up screw nuts on either side of the conveyor allows belt tracking adjustments to be made without affecting belt tension. Adjust the take-up screw nuts only 1/4 turn at a time. Then allow time for the belt to react to the adjustments before proceeding further. Try to avoid over-adjustments.

NOTE: Make sure wrench is below surface when brushing.

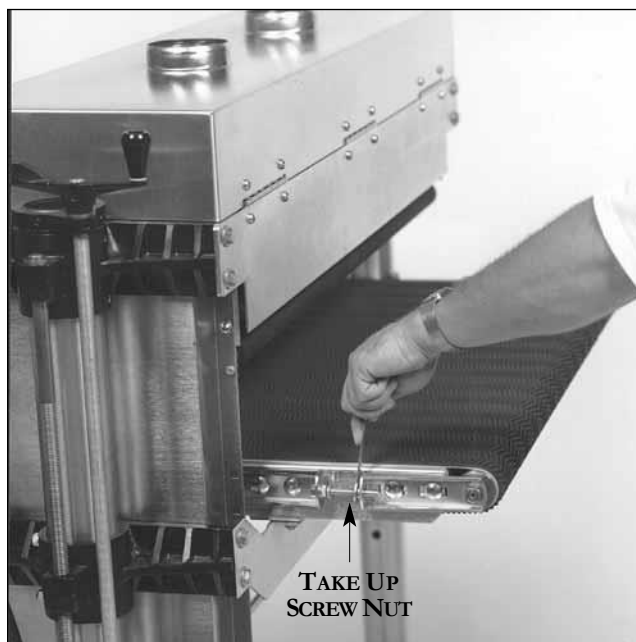

Fig. 9. Adjusting conveyor belt tracking.

OPERATING

Before using your SUPERBRUSH, review the previous pages in this manual on initial set-up and adjustment. In this section, you will learn how to operate the machine. Note that connecting the machine to an adequate dust collection system is necessary before operating the unit.

The SUPERBRUSH offers considerable control and versatility through infinitely variable brush speed and feed rate. Experiment with both to find the proper sander performance for a given application. Varying the brush speed makes the brush more or less aggressive. Too aggressive on the brush may tend to raise the grain or round edges. Sometimes it may be better to make two or more passes with a less aggressive brush or setting.

The brush is rotating against the direction of feed; therefore, the leading edges of contours will receive more sanding than trailing edges. Stock should be reversed on subsequent passes to sand all surfaces. Stock may also be fed at an angle to allow more brush penetration on the sides.

BASIC OPERATING PROCEDURES

After you have connected the machine to a dust collection system, you are ready to begin to use the

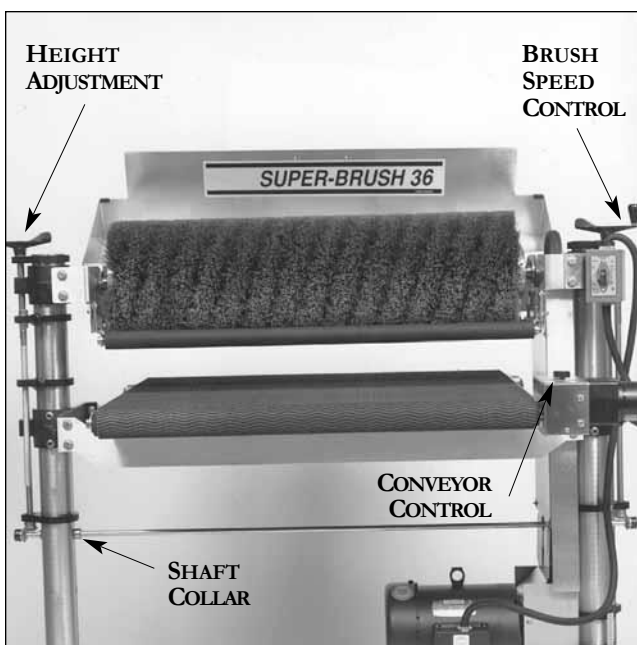

Fig. 10. Operating controls.

SUPERBRUSH. The basic operating procedure for the SUPERBRUSH models is as follows (Fig. 10):

1. Set depth of cut/bristle contact (page 10).
2. Set tension rollers to type of stock being sanded (See Tension Roller Adjustment below and Fig. 11)
3. Start sanding brush and select slow brush speed (page 8).
4. Start conveyor and select feed rate (page 10)
5. Start dust collector system.
6. Feed stock through unit.
7. Gradually increase brush speed until the desired finish is achieved (Fig. 8).

To feed stock through the SUPERBRUSH, rest and hold the stock to be sanded on the conveyor table, allowing the conveyor belt to carry the stock into the brush. Once the stock is halfway through, reposition yourself to the outfeed side of the machine to receive and control the stock as it exits the unit.

TENSION ROLLER ADJUSTMENT

Spring loaded infeed and outfeed Tension Rollers (Fig. 11) are provided to maintain downward pressure on stock being sanded and to prevent slippage of the stock on the feed conveyor. When properly set, the Tension Rollers should engage or raise up about 1/8" to accommodate the stock being brushed.

The Tension Rollers can and must be adjusted to accommodate flat surfaced stock vs highly contoured surface stock. If the Depth Gauge is properly calibrated (page 11), Tension Roller height is adjusted as follows: Note: Make sure brush head is appropriate for application and contact.

Flat Surfaced Stock: Set the bottom of the tension rollers even with the bottom of the brush. Loosen the four Tension Roller locking knobs (Fig. 11). Raise the table to the "0" mark on the Depth Gauge. At this position, the brush and Tension Rollers are resting on the table surface. Lock all four Tension Roller knobs. For example, to brush a 3/4" thick flat board, lower the table to 5/8" on the Depth Gauge. This allows 1/8" for Tension Roller engagement and 1/8" brush penetration.

Contoured Surface Stock: (Example: A 3/4" thick piece of molding with 3/8" of molding relief.) Loosen all four tension roller locking bolts (Fig. 11). Adjust the conveyor table 1/4" into the bristle tips (measure with a ruler from "0" mark on depth gauge.). At this position, the tension rollers are resting on the table surface and are positioned 1/4" above the bottom of the brush. Lock all four Tension Roller locking bolts. To brush the piece, lower the table to the 3/8" position on the Depth Gauge. This allows for 1/8" of tension roller engagement and 3/8" of brush penetration.

SELECTING STOCK FEED RATES

Selecting the proper feed rate is essential to proper brushing. Feed rate controls the duration of brushing on a particular spot. A slower feed rate allows more brushing to occur. In some instances, a slow feed rate and slow brush speed may produce the same result as a fast feed rate and fast brush speed. The variable feed rate control of the conveyor belt adjusts the load on the machine; it can be infinitely adjusted for maximum operating performance. A faster feed rate allows faster brushing but fewer revolutions of the brush per inch of sanding. A slower feed rate provides more revolutions of the brush per inch of sanding (Fig. 10).

The best feed rate will depend on a number of factors, including type of stock, brush, depth of cut used, and whether the stock is fed directly in line with the conveyor bed or at an angle.

When using a wire brush for "distressing" wood, a brush speed of 400-600 RPM with light contact of bristles and a moderate feed rate generally leaves the best finish.

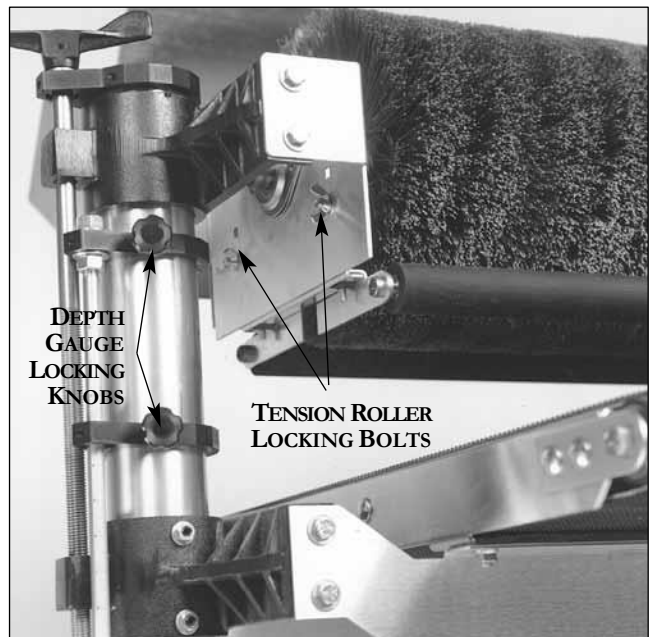

Fig. 11. Tension roller and depth gauge adjustment.

SETTING BRUSH DEPTH OF CUT/CONTACT

SuperMax Tools tests sample applications for all customers before selling a SUPERBRUSH. We recommend following the suggest RPM, contact and conveyor settings outlined in the sample letter. If you have questions about your application(s) or your needs change, please contact SuperMax Tools for updated information or new sample testing, as brush types, materials, etc. may have changed.

The information and suggestions listed below are not specific to any application and may have changed since printing. Please call SuperMax Tools if you have questions.

When a nylon or wire brush is worn and needs changing, the bristles will either have fractured and the brush head looks "bald" or the bristle length has worn and the bristles are too short for effective brushing.

When an abrasive or cloth brush is worn, the brushing material will become smooth or the brush will be considerably smaller in diameter as compared to new. Cloth brush heads may only need cleaning to rejuvenate the cloth. Please call SuperMax Tools if you have any questions. Brush life can vary considerably, due to RPM, contact, type of brush, and material being brushed.

Many types of brush heads may be rewound with new bristles or re-equipped with new brush material. Please contact SuperMax Tools if you have questions about a new or re-wrapped brush head.

Some types of brush heads, some fladder brushes, for example, will allow changing of the brush material by the operator, thus eliminating the need to send the brush head out for re-wrapping. Please call SuperMax Tools if you have any questions about re-wrapping a brush.

When using a wire brush for “distressing” wood, slowing brush RPM, using light contact and a moderate feed rate generally will give the best finish and longest brush life.

When using a wire brush on metal, it is important to use a light contact of the bristle tips.

Wire brushes frequently flipped end for end, to keep the wire from bending in one direction, will extend brush life. **Caution**, if you choose not to flip the brush frequently, it is better not to flip the brush at all.

Nylon Brushes. “Dress” tips of bristle brush periodically to maintain uniform brush wear and to expose new grit on the ends of the fiber.

Dressing Instructions:

Staple a wide sheet of 60 grit sandpaper to a 1/2” thick flat wood surface. Strips of narrow sandpaper can also be used. Raise the brush so the tips of the bristles contact the sandpaper by 1/32”. Set the conveyor speed to approximately 50% feed rate. Pass the abrasive loaded board through the machine until the brush fibers are sharp and even.

DEPTH GAUGE OPERATION

The depth gauge (see Fig. 11) measures the distance between the conveyor table and the bottom of the sanding brush. The sanding brush must be parallel to the conveyor bed surface. To calibrate the depth gauge, loosen the locking knob of the lower depth gauge casting so it rests on top of the table support casting. Raise the conveyor table until it touches the sanding brush. Then loosen the locking knob of the upper depth gauge casting and position the “0” mark of the scale even with the top of the lower depth gauge casting. Lock the upper depth gauge casting in position.

Once calibrated, the locking knob of the lower depth gauge casting can be loosened, allowing the lower depth gauge casting to ride on top of the table support casting. The depth can then be read where the scale enters the lower depth gauge casting. The depth gauge can also be used as a stop gauge as follows: Position the lower depth gauge casting along the scale to a desired finish thickness. Then lock the lower depth gauge casting with the locking knob to prevent the conveyor table from being raised above that point

MONTHLY MAINTENANCE

For best results, perform the following recommended maintenance procedures on a monthly basis:

- Lubricate conveyor bushings and check for wear.
- Lubricate all moving parts, such as threaded rods, washers, and column tubes.
- Clean dust from the conveyor belt.
- Blow dust from the motors.
- Check all set screws for tightness on parts such as brush support castings, bearings, conveyor coupler, castings, pulleys, and miter gears.
- Clean brush, if applicable.

TIPS FOR MAXIMUM PERFORMANCE

The versatility designed into the SUPERBRUSH allows it to be used for a wide-ranging variety of tasks that will boost the return on your investment. Learning to use its multiple adjustments and controls will allow you to fine-tune the machine for maximum results, regardless of the job to be done. The best results come from experimenting with different machine adjustments to fit the job at hand. Following is a listing of useful tips which can help you improve performance of your brush sander.

Dust Collection. When connecting dust collectors, remember that straight pipe will not restrict airflow as much as flexible tubing. Also, Ys and elbows will restrict airflow less than Ts. When connecting to the dual ports of the SUPERBRUSH 36, use a larger diameter pipe to the machine, and then split to two 4" hoses connected to the ports. An alternative is to use two separate 4" lines running to the ports; **do not** use only one 4" line and split it by the machine.



Fig. 12. Offset stock feeding angle.

Brushing Multiple Pieces At Once. When brushing multiple pieces simultaneously, make sure to stagger (step) the pieces across the width of the conveyor belt. This provides better contact with the tension rollers. Try to only process multiple pieces of similar thickness. If there is a significant thickness difference, the thinner pieces can slip on the conveyor belt if they do not contact the tension rollers. When brushing high stock, special care is needed to prevent tipping.

Brushing Imperfect Stock. To avoid personal injury, take special care when brushing stock that is twisted, bowed, or otherwise varies in thickness from end to end. If possible, support such stock as it is being brushed to keep it from slipping or tipping. Use extra roller stands, help from another person, or hand pressure on the stock, to minimize potentially hazardous situations.

Stock Feeding Angle. Some pieces, because of their dimensions, will need to be fed into the machine at a 90° angle (perpendicular to the brush). However, even a slight offset angle of the stock can provide for more effective brushing on some stock (Fig. 12).

Keeping the Machine Clean. For best results, make cleaning the machine a regular shop procedure. Allowing excess build-up of dust and debris can adversely affect performance, slippage on the conveyor belt, and/or the accumulation of material on the brush which can throw off the center of balance. Leave the dust collector on when cleaning dust from the brush. Also brush the conveyor belt after cleaning operations. If not cleaned, the conveyor belt could allow stock to slip during brushing operations.

TROUBLESHOOTING

Any operating problems with the SUPERBRUSH will likely occur most often during the period that you are becoming familiar with its components and their adjustments. If you are experiencing a problem affecting the machine's brushing

performance, check the following listings for potential causes and solutions; it may also pay to review the previous sections in this manual on setting up and operating your machine.

TROUBLESHOOTING GUIDE: MOTORS

Problem	Possible Cause	Solution
Motors do not start.	1. Main power cord unplugged from receptacle.	Plug in primary power cord.
	2. Circuit fuse blown or circuit breaker tripped.	Replace fuse or retrip breaker (after determining cause).
Brush motor overloads.	1. Inadequate circuit.	Check electrical requirements (page 6).
	2. Machine overloaded.	Use slower feed rate; slower brush RPM; reduce depth of cut.
Conveyor motor oscillates.	1. Motor not properly aligned.	Loosen housing bolts, run motor, retighten bolts.
	2. Shaft collar or bushing worn.	Replace shaft collar or bushing (page 5).
	3. Drive roller bent.	Replace drive roller (page 20).
Brush motor or conveyor gear motor stalls.	1. Excessive depth of cut.	Reduce depth of cut; decrease brush speed; reduce feed rate.

TROUBLESHOOTING GUIDE: CONVEYOR		
Problem	Possible Cause	Solution
Conveyor rollers run intermittently.	1. Shaft coupling loose.	Align shaft flats of gear motor and drive roller; (page 5) tighten shaft coupling set screws.
Conveyor belt slips on drive roller.	1. Improper conveyor belt tension.	Adjust belt tension (page 8).
	2. Excessive depth of cut.	Reduce depth of cut; reduce feed rate.
Stock slips on conveyor belt.	1. Excessive depth of cut.	Reduce depth of cut.
	2. Tension rollers too high.	Lower tension rollers (page 9).
	3. Excessive feed rate.	Reduce feed rate.
	4. Dirty or worn conveyor belt.	Clean or replace conveyor belt.
Conveyor belt tracks to one side, or oscillates from side to side.	1. Belt out of adjustment.	Readjust belt; (page 8).
	2. Drive or driven conveyor belt rollers misaligned.	Readjust (page 20).
	3. Conveyor table not flat and square.	Readjust by leveling machine (page 7).
	4. Conveyor belt worn.	Replace conveyor belt (page 20).
	5. Drive roller worn or damaged.	Replace drive roller. (page 20).
	6. Roller bushings elongated due to excessive wear.	Replace bushings. (page 20).

TROUBLESHOOTING GUIDE: MACHINE		
Problem	Possible Cause	Solution
Brush height adjustment works improperly.	1. Improper adjustment of height control.	Readjust height control (pages 7 and 16).
Knocking sound while running.	1. Bearing out of alignment.	Rotate bearing (page 22)
	2. V-belt worn.	Replace V-belt (page 21).
	3. Pulleys wobbling or out of round.	Tighten set screws or replace pulley (page 22).
	4. Set screws loose in pulley or bearing.	Retighten set screws.
	5. Bearing worn.	Replace bearing (page 22).
Sniping of wood (gouging near end of board).	1. Inadequate support of stock.	Use roller stands to support stock.
	2. Conveyor drive or driven rollers higher than conveyor bed.	Readjust rollers (page 20).
Burning of wood. or melting of finish	1. Feed rate too slow.	Increase feed rate.
	2. Excessive depth of cut	Reduce depth of cut, decrease brush RPM.
Gouging of wood.	1. Conveyor belt is too loose.	Adjust belt tension.
	2. Excessive depth of cut.	Reduce depth of cut, decrease brush RPM.
	3. Wood slipping on conveyor due to lack of contact.	Use alternate feeding procedure (page 12).

SERVICING

The basic adjustment procedures for your machine are covered under Setting Up Your SUPERBRUSH, page 6. Review that section first. If following the general instructions does not solve a specific problem or result in smooth operation, also check Troubleshooting Your SUPERBRUSH, page 13. Below are suggested procedures to follow when more thorough readjustment or replacement is necessary.

ADJUSTING HEIGHT CONTROLS

Height adjustment problems may be the result of not loosening the set screws in the table support castings before attempting operation. (This is covered on page 5 of this manual, and also on the separate unpacking sheet which was shipped with your machine.) If the set screws were not loosened as instructed, do so now before proceeding further. Also make sure all moving parts of the height adjusting mechanism are well lubricated, including the miter gears, column tubes, and threaded height adjusting screws.

When troubleshooting the height adjustment mechanism, first check the conveyor table for level (see page 7). Then test the height adjustment mechanism (See Fig. 13). If it does not operate

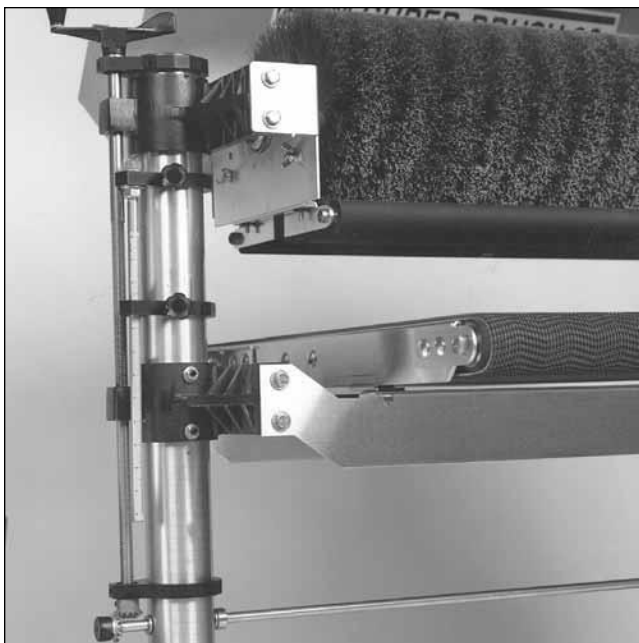

Fig. 13. Table support casting set screws.

easily, further adjustments may be necessary, as outlined below. Following these steps should result in smooth operation.

Readjustment Procedure

1. Loosen the set screws located at the front of the table support castings (Fig. 3).
2. Lubricate thoroughly by applying penetrating lubricant to the table support castings where they contact the column tubes, and to all contact points of adjusting screws and transfer rod (Fig. 15). Also apply grease or oil to the miter gears.
3. If the height adjustment feels stiff, check for misalignment of adjusting screw supports and the brush support castings which could cause binding on the adjusting screw (Fig. 5). These castings can be adjusted by loosening the set screws which secure them to the column tubes. Realign the adjusting screw supports by loosening the two set screws that hold them to the column tubes and rotate to the proper position.
4. The adjusting screw supports located immediately below the height adjustment handle and the left

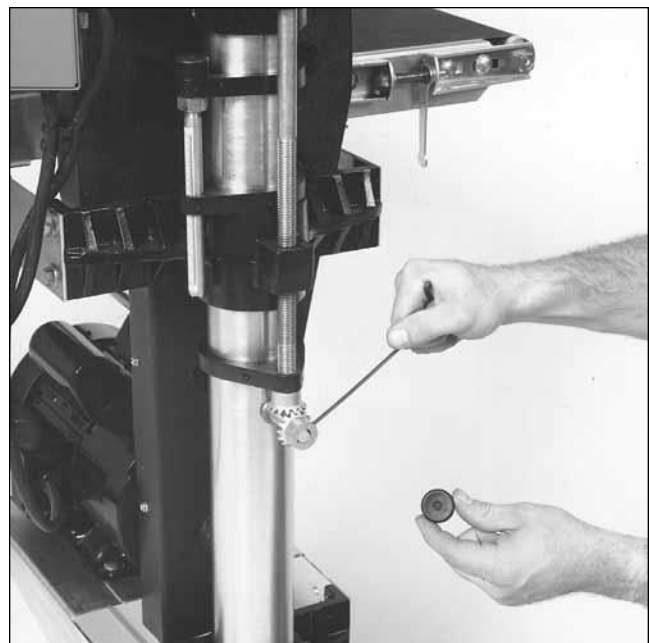

Fig. 14. Adjusting miter gears for proper mesh.

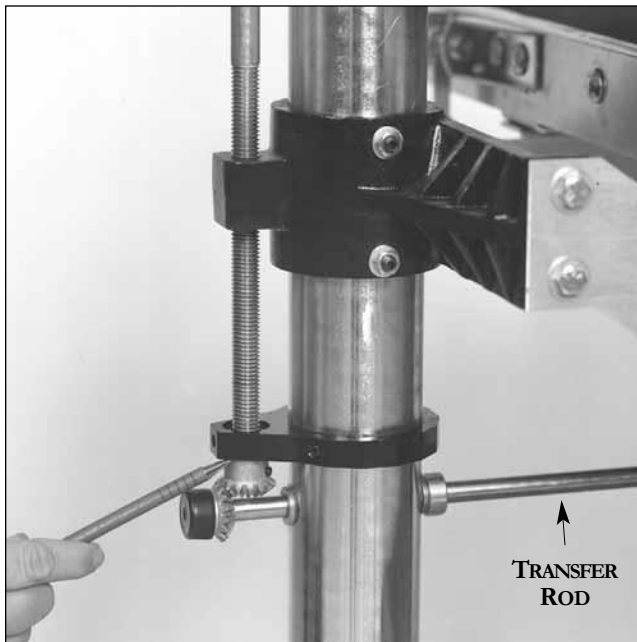

Fig. 15. Miter gear below adjusting screw support.

(outboard) brush support casting (Fig. 15) must both be set at the proper height along the column tubes so the height adjusting screws provide for proper miter gear alignment. Before adjusting these parts, tighten one set screw in the table support castings (Fig. 5) to hold the height adjusting screw in position during adjustment.

Also check to see that the column tubes are centered inside the bore of the table support castings (Fig. 5). If not, loosen the casting bolts and tighten the set screws at the front of table support casting to center the tube. Retighten the bolts and loosen the set screws.

5. If the height adjustment mechanism feels rough, check the miter gear (Fig. 14) alignment. The miter gears can be adjusted on their shafts by loosening the set screws on the gears. Check and adjust so that the gear mesh is not too tight or too loose, and that the gear teeth align with the opposing gear. Note that the shaft collars located on the transfer rod should be adjusted to control the lateral movement of the transfer rod to maintain accurate miter gear alignment and mesh.

The mesh of the miter gears should be smooth and even. If not, adjust the gears for good mesh. Measure the space between the miter gear and the adjusting screw support that holds the height adjusting screw in place (Fig. 15). The distance



Fig. 16. Height controls on outboard side.

should be $1/64$ " or less. If there is excessive space, move the adjusting screw support to the proper distance above the miter gear and retighten. Loosen the set screws in the table support castings (Fig. 3) and test for smooth operation.

6. Next, check the position of the height adjusting screw. First raise the conveyor table. Then check the retaining-clip and washer at the top of the height adjusting screw on the right (inboard) side, and under the height adjustment handle on the left (outboard) side of the machine (Fig. 5). On both sides, the washer and handle should be snug on the casting and retaining the washer. If there is a space between the washer and the casting, tighten one set screw in each of the table support castings. If one height adjusting screw is loose, remove the miter gear from the transfer rod on that side. Turn down the threaded height adjusting screw rod until it is snug on the washer. Make sure both sides are snug on top. Reinstall the miter gear and tighten. Loosen the set screws in the table support castings and test for smooth operation.

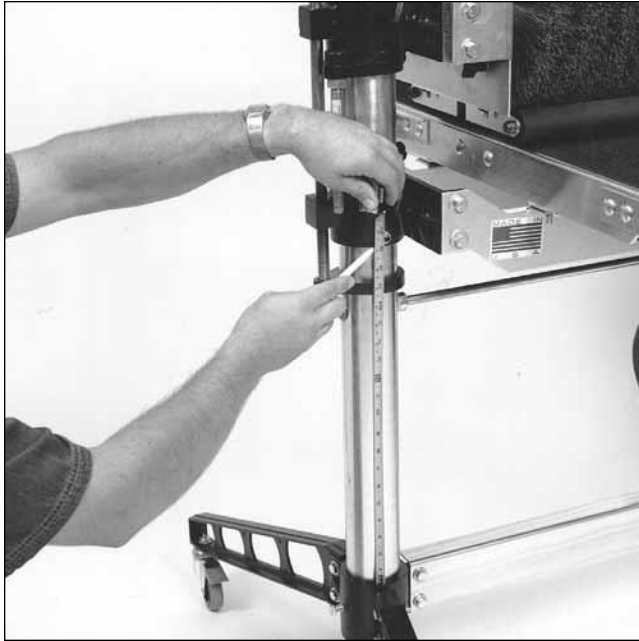

Fig. 17. Adjusting table support castings.

LEVELING TABLE

To measure levelness of table, measure the distance between the top of the base casting (Fig. 17) and the bottom of the table support castings. This measurement should be the same for both sides. If it is not the same, adjust as follows:

Remove the plastic cap from the miter gear (Fig. 14) on the outboard side of the machine. Loosen the set screw of the miter gear and slide it back to disengage it from the miter gear of the adjusting screw. Turn the adjusting screw handle to raise or lower the outboard side of the table so that the measurement taken above equals the inboard side of the table. After adjusting is complete, re-engage miter gear making sure that miter gear set screw is aligned with flat on cross bar shaft.

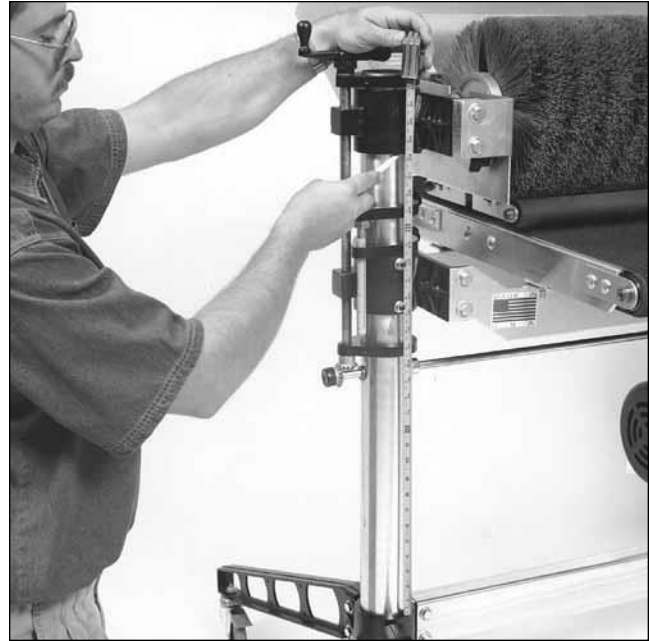

Fig. 18. Comparing brush support casting heights.

MITER GEAR ALIGNMENT

If height adjustment mechanism does not operate easily, perform the following checks or adjustments:

1. Loosen set screws located on table support castings. (Fig. 3).
2. Lubricate thoroughly! Apply penetrating lubricant to table support castings where it contacts the column tubes, and to all contact points of adjusting screws and cross bar. Apply grease/oil to miter gears.
3. Check miter gear alignment. Check and adjust gears so that gear mesh is not too tight nor too loose and that gear teeth align with opposing gear. The miter gears can be adjusted on their shafts by loosening the set screws on the gears. Note that set screws **MUST** align with flat of shaft. To raise or lower the vertical miter gears, the adjusting screw support, located immediately above the gears, must also be raised or lowered to ride on top of the gear to maintain adjusting screw position.

If vertical miter gear is raised to its highest position, then the adjusting screw (Fig. 5) must be raised, if necessary, to obtain proper gear alignment. Raise adjusting screws as follows:

Inboard follow screw (right): Loosen and raise adjusting screw support (Fig. 5). Loosen both set screws located on front of brush support casting and raise inboard side of brush, screw and table to desired height. Retighten set screws of brush support casting (Fig. 3) and re-position and tighten adjusting screw support at top of miter gear. The brush and conveyor table must be re-aligned after this adjustment. See Leveling Table and Brush Alignment (page 7).

Outboard Adjusting Screw (left): Loosen and raise adjusting screw support (Fig. 5) above miter gear. Tighten set screw at front of outboard table support casting. Loosen set screw and disengage opposing horizontal miter gear. Turn adjusting screw handle to raise screw to desired height. Re-position adjusting screw support to bottom of handle. Re-position adjusting screw support (Fig. 17) to top of miter gear. Loosen set screws of table support casting (Fig. 3). Re-engage opposing horizontal miter gear. NOTE: Shaft collars (Fig. 10) located on the transfer rod should be adjusted to control lateral movement of the transfer rod to maintain accurate miter alignment and mesh.

4. Check and adjust for misalignment of adjusting screw supports (Fig. 5) and brush support castings which could cause binding on the adjusting screw. These castings can be slightly rotated by loosening the set screws which secure it to the inside of the column tubes. NOTE: The adjusting screw support (Fig. 5) located immediately below the height adjusting handle and the outboard brush support casting, must be set at the proper height along the column tubes to position the adjusting screws so that there is proper miter gear alignment. Before adjusting these parts, tighten one set screw of table support castings to maintain adjusting screw position during adjustment.

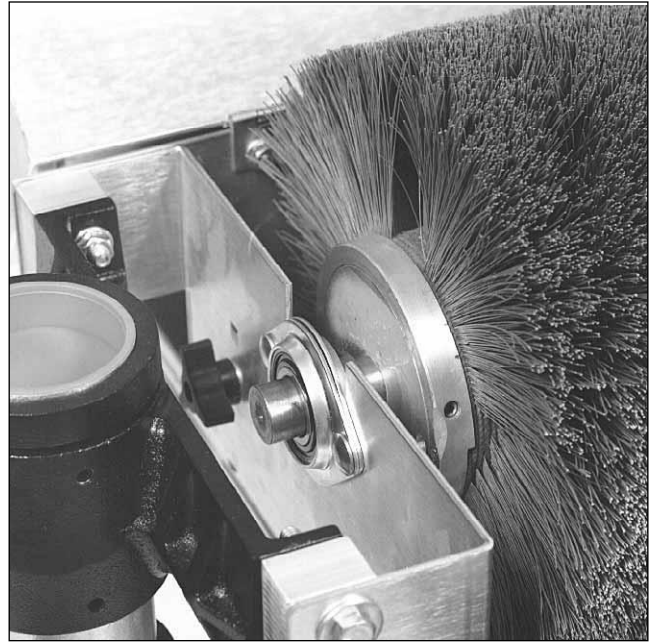

Fig. 19. Removing brush head.

BRUSH SPEED ADJUSTMENT

If the brush speed adjustment does not operate easily, perform the following check or adjustments:

1. Loosen set screws located on front of motor support casting (Fig. 3).
2. Lubricate thoroughly!! Apply penetrating lubricant to motor support casting where it contacts the column tubes and to all contact points between adjusting screw and adjusting screw supports (Fig. 5).
3. Improper alignment of adjusting screw supports may cause binding on the adjusting screw. Loosen both set screws on each adjusting screw support to rotate or adjust screw supports. Note that adjusting screw supports control both lateral and vertical movement of the adjusting screw mechanism and must be adjusted accordingly.

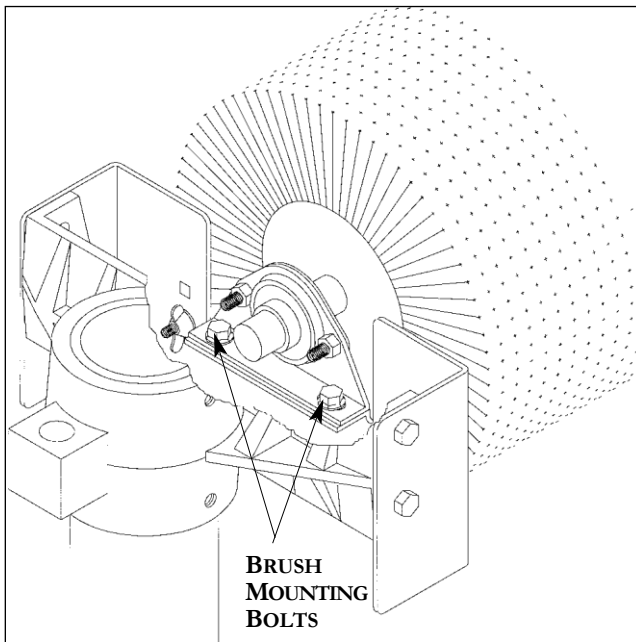

Fig. 19A. Removing brush head (some models).

CHANGING OR REPLACING BRUSH

Changing the brush on the SUPERBRUSH is relatively simple. To begin, first disconnect power source to the machine. Lower the motor to its lowest position using the brush speed control handle. Raise the motor to its highest position. This loosens the V-belt tension so the V-belt can be lifted off the driven pulley, pulled back and placed under the control handle to hold it out of the way. Loosen and remove bearing bolts (Fig. 19 and 19A, depending on model. See also page 23 and Fig. 25.) Lift brush out of machine. Loosen set screws of bearing collars and pulley. Remove bearings and pulley and install on replacement brush.

Install replacement brush in machine and center brush before tightening bearing bolts. Tighten bearing set screws after bearing bolts are tightened. Install V-belt on driven pulley and adjust pulley for proper V-belt alignment before tightening pulley set screw.

REPLACING CONVEYOR BELTS

To replace the conveyor belt, the conveyor assembly must be removed from the machine. Lower the conveyor table to its lowest position with the height adjustment handle. Turn off power source to machine. Place conveyor motor assembly on top of dust cover (see #3, page 5). Loosen the conveyor take-up screws (Fig. 21) to relieve belt tension and slide the driven roller fully inward. Remove the four bolts that attach the conveyor assembly to the table mount brackets (see Fig. 21). Lift the conveyor and remove it from the machine by sliding the conveyor out toward the front of the machine. Avoid tearing the belt on any edges underneath the conveyor bed during removal. Reverse the procedure for re-installation.

Note: If the conveyor belt continually tracks to one side of the machine, first try reversing the belt on the conveyor bed. If this doesn't remedy the problem, place a level on the conveyor bed to make sure the conveyor bed is not twisted. If it is twisted, see page 7 for instructions on squaring up the bed. If squaring up the bed does not remedy the problem, proceed with the steps below:

Step 1. Check the conveyor drive and driven roller to make sure it is parallel to the surface of the conveyor bed. To do this, first center the conveyor belt on the bed. Then lay a straight-edge on the exposed edge of the conveyor table on the left (outboard) side, extending it over the drive or driven roller. Note the distance between the drive or driven roller and the straight-edge.

Step 2. Now repeat Step 1 on the right (inboard) side of the conveyor. Compare the measurements from side to side. If they are not equal, loosen one of the brackets that hold the drive or driven roller in place. Tip this bracket until the distance between the drive roller and the straight-edge are equal from side to side, then tighten the bracket.

Conveyor Belt Tension: To adjust the tension of the conveyor belt, first adjust the take-up screw nut (Fig. 21) on both sides of the conveyor to obtain approximately equal tension on both sides of the belt when taut. Insufficient belt tension will cause slippage of conveyor belt on the drive roller during sanding operation. The conveyor belt is too loose if it can be stopped by hand pressure applied directly to the top of the conveyor belt. Excessive belt tension can result in bent rollers, premature wearing of the bronze bushings or conveyor belt

Conveyor Belt Tracking: Belt tracking adjustments are made while the conveyor belt is running. After the proper belt tension is obtained (see above), turn the conveyor unit on and set it at the fastest speed setting. Watch for a tendency of the conveyor belt to drift to one side of the conveyor. To adjust the belt tracking, tighten the take-up screw nut (Fig. 21) on the side the belt is drifting toward, and loosen the take-up screw nut on the opposite side. Adjusting the take-up screw nuts on either side of the conveyor allows belt tracking adjustments to be made without affecting belt tension. **Note:** Adjust the take-up screw nuts only 1/4 turn at a time. Then allow time for the belt to react to the adjustments before proceeding further. Try to avoid over-adjustments.

REPLACING V-BELT

To change the V-belt on the SUPERBRUSH, first disconnect power source to machine.

1. Lower the main motor to its lowest position using the brush speed control handle. Raise the motor to its highest position. This will loosen the V-belt in the drive pulley so the V-belt can be lifted off the driven pulley.
2. Remove the miter gear from the right (inboard) side of the transfer rod (Fig. 14). (If E clips are attached to the rod, remove both at this time.) Now loosen the shaft collar on the left (outboard) side of the rod, and pull the rod back enough so the V-belt can be removed. (Make sure to catch the nylon washer which will drop off the transfer rod.)
3. Remove the inner half of the pulley guard by removing the six screws holding the inner half to

the outer half. Remove the inner half of the pulley guard.

4. Remove the top two bolts holding the top of the outer pulley guard. The outer half of the pulley guard can be removed by pulling it up and out through the head assembly.
5. Remove V-belt from drive pulley. If there is not enough clearance to remove V-belt loosen the four bolts securing the main motor to bracket. Note location of motor before sliding motor out of the way for ease of reassembly. Note the routing of the old V-belt: now remove the old V-belt and replace it with the new V-belt (Fig. 23 and 24).

NOTE: If the V-belt will not fit between the drive pulley and the brush support casting, loosen or remove the bolts holding the bearings. Lift brush enough to allow V-belt to be removed. After installing new V-belt, retighten bolts.

Machine Reassembly

1. To reassemble the unit after replacing the V-belt, first reassemble the pulley guards.
2. Place the transfer rod back through the machine and reinstall the nylon washer. Tighten the shaft collar (install both of the E clips if so equipped). Reinstall the miter gear on the transfer rod, making sure the set screw is centered on the flat of the rod.
3. Adjust the tension on the V-belt by lowering the motor using the brush speed control handle.
4. Make sure that the V-belt is in alignment. Also check that all belts are tight before using the SUPERBRUSH.

ROTATING/REPLACING BRUSH BEARINGS

Replacing the permanently lubricated bearings on the SUPERBRUSH is a relatively straight-forward procedure. Bearings should be replaced when they allow excessive play of the brush, make excessive noise, or otherwise indicate failure.

Note that if clicking noises in the bearings are a problem, rotating may be a solution instead of replacement, as follows:

BEARING ROTATING

Step 1. Loosen the set screws in the bearing collar. Leave the set screw wrench in one of the set screws. Then rotate the brush within the bearing and tighten the set screws (Fig. 19 and 20).

Step 2. If the clicking persists, or if the brush shaft is tight in the bearing and cannot rotate, then loosen the two bolts holding the bearing and the flange for the bearing. Now repeat Step 1. After the brush is rotated within the bearing, tighten the flanges first and then the set screws. After the machine has run for a half hour, stop to check that the set screws and bearing bolts are tight.

Bearing Replacement:

1. Disconnect power source to the machine.
2. Lower motor to its lowest position using the RPM adjustment handle. Then raise motor to its highest position using the RPM adjustment handle. This loosens the V-belt tension so the V-belt can be lifted off the driven pulley.
3. Raise conveyor bed until the brush rests on bed.

If replacing both bearings, begin with bearing on the left (outboard) side.

Replacing Left (Outboard) Bearing:

Make sure power is disconnected to the machine.

1. Remove the outer half of the bearing flange. Loosen the set screws in the bearing collars and remove the bearing.
2. If the shaft of the brush is rough from the set screws, use emery cloth or sandpaper to smooth down any raised edges. Slide the new bearing on the shaft, but do not tighten the set screws yet.
3. Install the outer half of the original bearing flange and tighten the bolts. Then tighten the set screw in the bearing collar.

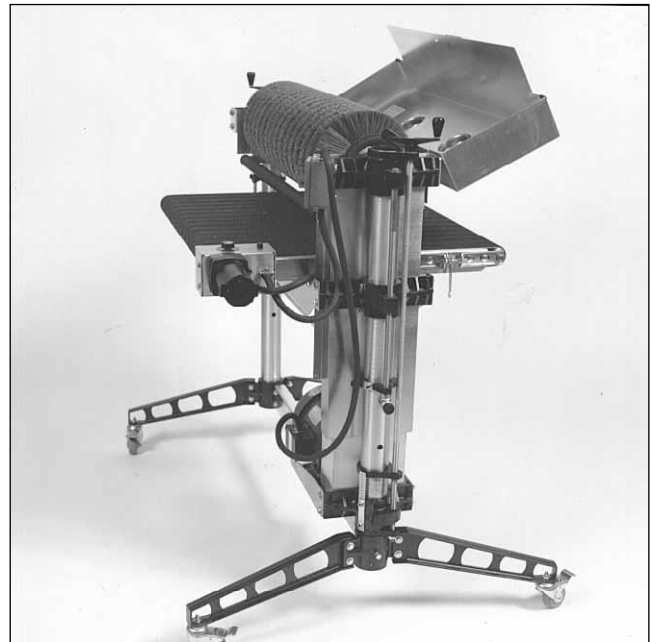

Fig. 20. Conveyor belt replacement.

If the left (outboard) bearing is the only one that needs changing, proceed to reassemble the unit. You can check the brush at this point by lowering the conveyor bed and spinning the brush by hand. This will help determine if the inboard bearing needs to be changed to eliminate noise or excessive play in the brush.

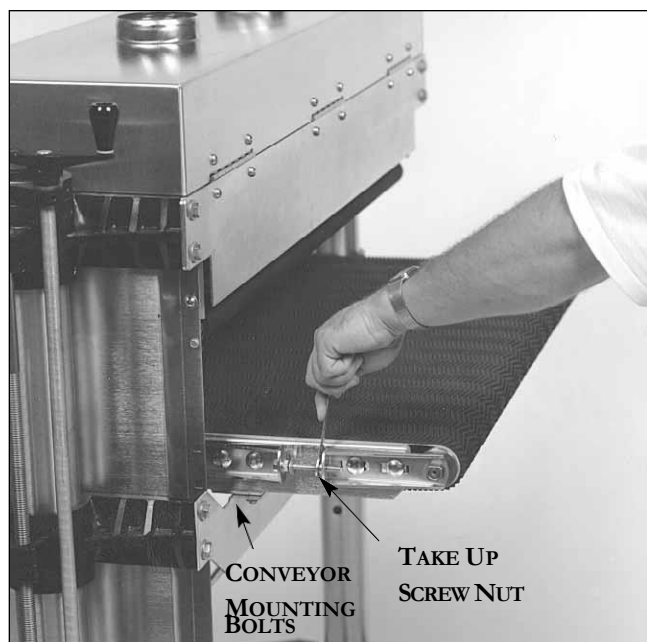

Fig. 21. Tensioning and tracking conveyor belt.

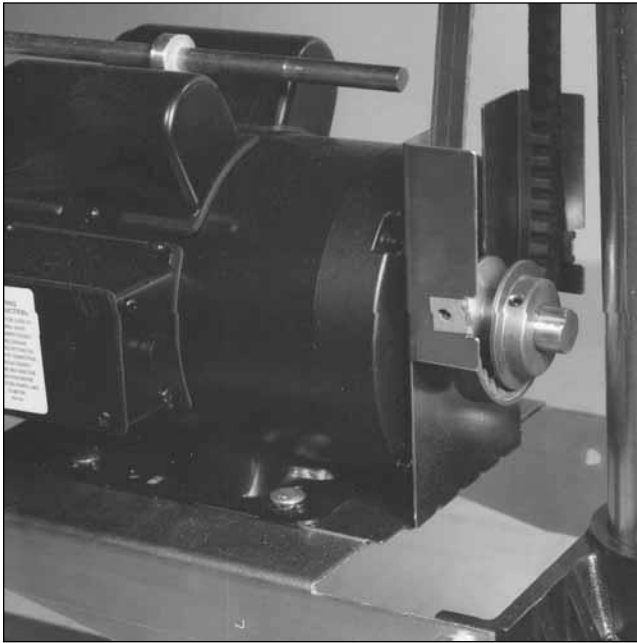

Fig. 23. Removing lower guard and transfer rod.

Replacing Right (Inboard) Bearing:

Disconnect power source to brush.

1. Lower motor to its lowest position using the RPM adjustment handle. Then raise motor to its highest position using the RPM adjustment handle. This loosens the V-belt tension so the V-belt can be lifted off the driven pulley.
2. Raise conveyor table so brush rests on conveyor.
3. Remove left (outboard) bearing by removing the two carriage bolts from bearing.
4. Remove the right (inboard) bearing by removing the two carriage bolts from bearing.
5. Remove V-belt from driven pulley.
6. Lift brush head out from machine.
7. Loosen set screws in bearing collar and driven pulley and remove from brush shaft.
8. Install new bearing and driven pulley. Do not tighten set screws at this time.
9. Install brush in machine and center before tightening bolts. Tighten bearing bolts and then set screws in bearings.
10. Install V-belt on driven pulley and adjust pulley for proper V-belt alignment before tightening pulley set screw.
11. Check the alignment of the brush to the conveyor system.

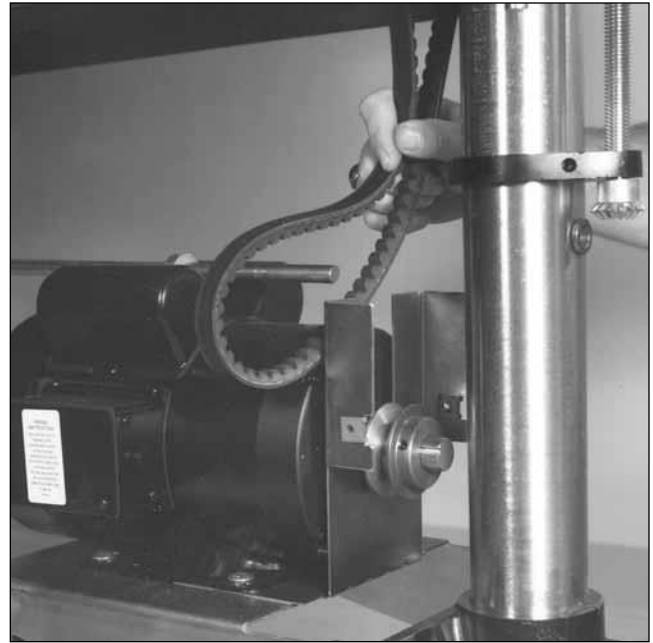

Fig. 24. Removing main motor V-belt drive.

REPLACING BRUSH HEAD

1. Lower motor to its lowest position using the RPM adjustment handle. Then raise motor to its highest position using the RPM adjustment handle. This loosens the V-belt tension so the V-belt can be lifted off the driven pulley.
2. Remove the bearing bolts (Fig. 19, 19A and 25) and lift brush out of machine. **Note:** Some models have two mounting bolts attaching the bearing housing down into the brush support bracket. These two bolts can be used to remove the brush head instead of the bolts through the bearing flange.
3. Loosen set screws in bearing collars and driven pulley and remove from brush shaft.
4. Install new bearings and driven pulley. Do not tighten set screws at this time.
5. Install brush in machine and center before tightening bearing bolts. Tighten bearing bolts and then set screws in bearings.
6. Install V-belt on driven pulley and adjust pulley for proper V-belt alignment before tightening pulley set screw.
7. Check the alignment of the brush to the conveyor system. (For instructions on this procedure, see page 7 of this manual).
8. Lower the conveyor and spin the brush by hand to make sure the brush shaft is not binding in the bearing. If the bearings bind, loosen the set screws

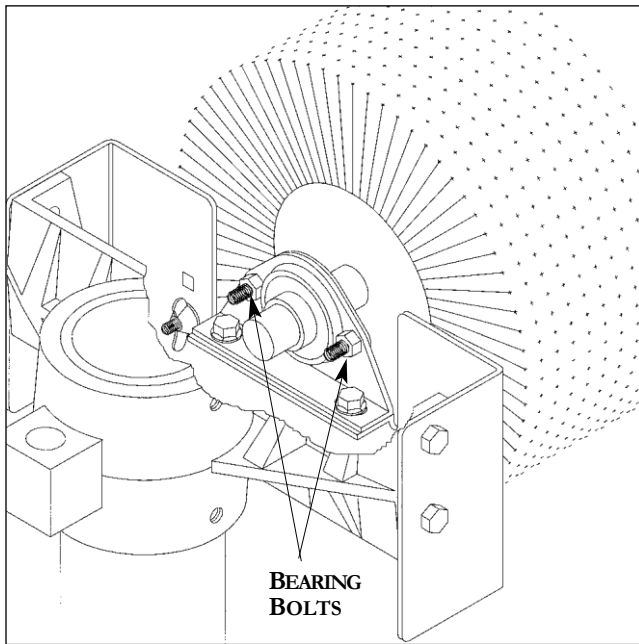

Fig. 25. Supporting brushes to remove bearings.

and the bearing flange for one bearing at a time. Spin the brush within the collar, then tighten the bolts in the bearing flange and then the set screws. 9. Test-run the SUPERBRUSH before brushing stock to check that all is operating properly and is aligned before brushing good stock. Also, stop the SUPERBRUSH after a couple hours of use and check the bolts and set screws to make sure they are seated properly.

REPLACING ELECTRICAL COMPONENTS

To replace either the variable-speed controller, or the conveyor motor, use the following disassembly procedure (Fig. 26 and pages 25 and 26):

Disconnect the power supply to the machine. Next, remove the bottom plate from the control box. Loosen the set screw in the shaft coupler, and then remove the four 5/16" bolts that hold the power feed motor assembly in place. Next, remove the assembly from the machine and turn it upside down to disconnect the leads from the components to be removed.

To replace the controller, remove the variable speed control knob. Remove the nut that holds the controller in place and pull the controller out of the housing. Install the new controller, referring to the correct electrical diagram and reverse the disassembly procedure.

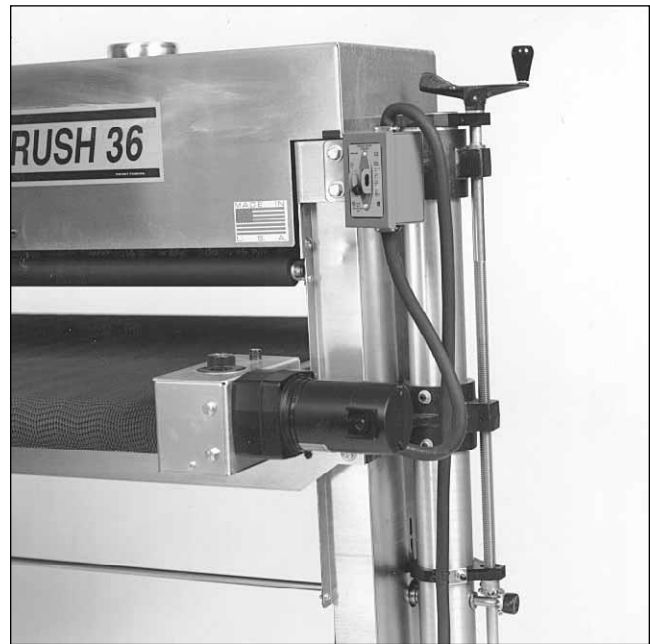

Fig. 26. Conveyor motor control box and brush on/off switch.

To replace on/off switch, make sure power is disconnected to sander. Remove the two screws holding the front cover of the switch in place. Disconnect and mark wire leads connected to switch mechanism. Remove switch from box and install new switch. Connect wires to new switch following the wiring diagram and marked wires. **IMPORTANT:** Make sure bare wire does not touch any other wire or the switch box when connected. Install switch assembly and cover.

To replace the conveyor gear motor, disconnect the two wire leads from the controller. Also disconnect the plastic grommet protecting the wires passing through the housing. Remove the four cap head set screws that hold the motor to the housing bracket. Remove the old motor and install new motor. Install the wiring leads according to the electrical diagram pertaining to the correct model (See following diagrams).

To replace conveyor fuse (Fig. 4), push and turn fuse cap 1/8 turn counter clockwise. Pull cap with fuse from base. Pull fuse from cap and replace with 3/4 amp fuse (pages 25 and 26). Place fuse and cap into base, push and turn 1/8 turn clockwise to secure.

SUPER BRUSH WIRING DIAGRAM 230 VOLT 1 PHASE, 60 HZ

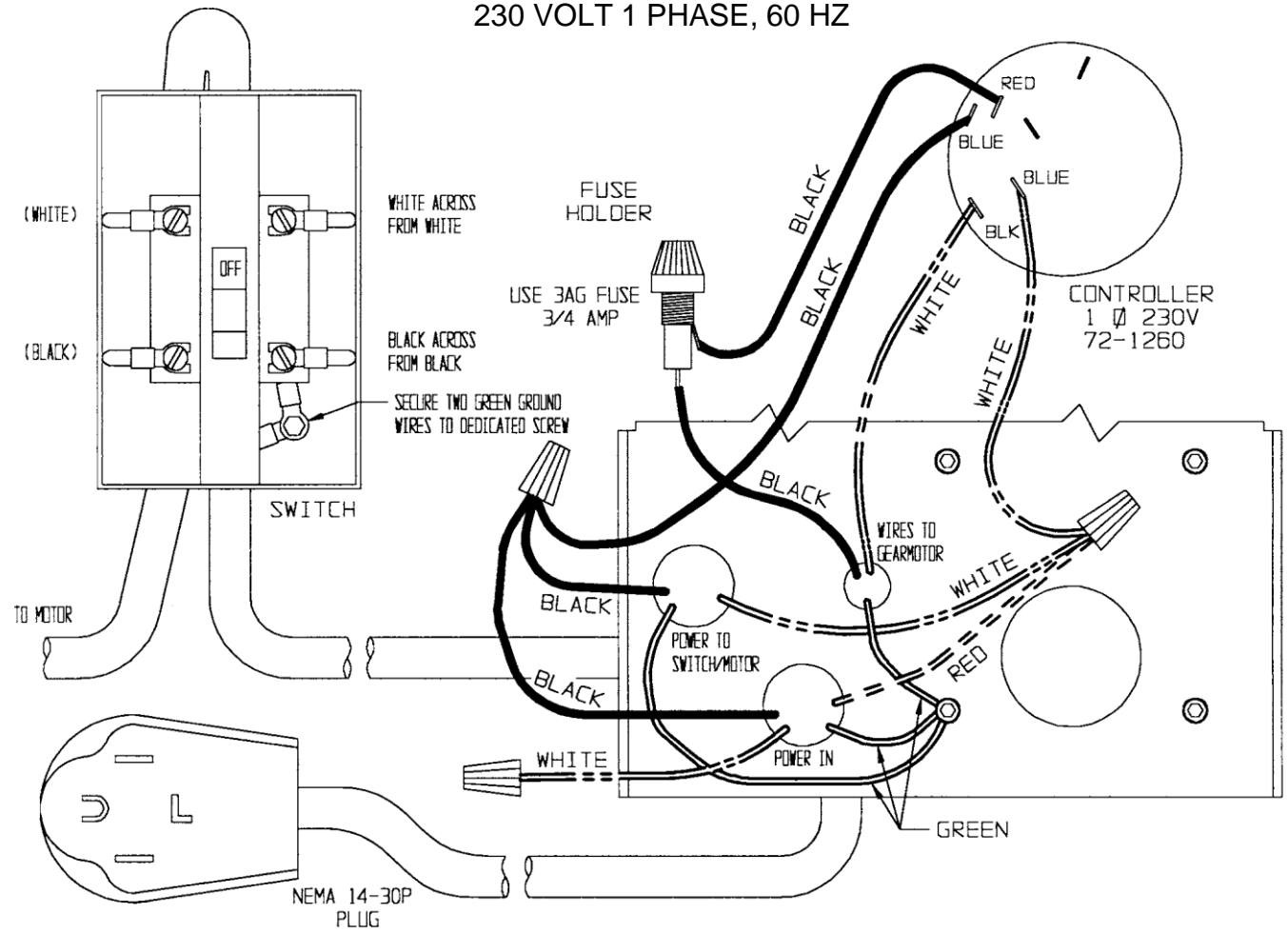

WARRANTY & REGISTRATION

Thank You!

Welcome to the Laguna Tools® group of discriminating machinery owners. We understand that you have a choice of where to purchase your machines and appreciate the confidence you have in the Laguna Tools® brand.

Through hands-on experience, Laguna Tools® is constantly working hard to make innovative, precision products. Products that inspire you to create works of art are a joy to operate and encourage your best work.

Laguna Tools®
Imagination, Innovation, and Invention at Work

Warranty & Registration

Every product sold is warranted to be free of manufacturer's defective workmanship, parts, and materials. For any questions about this produce, the intended use or what it was designed for, customer service, or replacement parts, please contact our customer service department:

Laguna Tools® Customer Service
744 Refuge Way, Grand Prairie, Texas 75050, USA
1-800-234-1976
customerservice@lagunatools.com
www.lagunatools.com/why/customer-service/
8AM. To 5PM PSF. Monday through Friday

For warranty claims or to report damage upon receiving-please reach out to our warranty department:

Laguna Tools® Warranty Service
744 Refuge Way, Grand Prairie, Texas 75050, USA
1-800-234-1976
customerservice@lagunatools.com
www.lagunatools.com/policies/warranty
8AM to 5PM PST, Monday through Friday

Registration

To prevent voiding this warranty, all products sold must be registered within thirty (30) days of receiving the product. Registering the product will enable the original purchaser to receive notifications about important product changes, receive customer service, and be able to file a warranty claim against defective workmanship, parts, or materials.



Who is Covered

The applicable warranty covers only the initial purchaser of the product from the date of receiving the product. To file such claims, the original purchaser must present the original receipt as proof of purchase.

What is Covered

The warranty covers any defects in the workmanship of all parts and materials that make up the machine unless otherwise specified. Any part determined by Laguna Tools® to have a defect will be repaired or replaced (and shipped), without charge. The defective item/part must be returned to Laguna Tools® with the complaint and proof of purchase in the original packaging that it was received in. In the event the item/part is determined to be not covered by this warranty, the customer will be responsible for the cost to replace the item/part and all related shipping charges

Warranty Limitations

This limited warranty does not apply to natural disasters, acts of terrorism, normal wear and tear, product failure due to lack of maintenance or cleaning, damage caused by accident, neglect, or lack-of inadequate dust collection. The warranty may be voided against proof of misuse/abuse, damage caused where repair or alterations have been made or attempted by others, using the product for purposes other than those described as intended use (unless with consent by Laguna Tools®), modification to the product, or use with an accessory that was not designed for the product. It is the responsibility of the user to understand basic machinery settings and procedures and to properly maintain the equipment in accordance with the standards provided in this manual.

Length of Warranty

All new machines and optional accessories sold through an authorized dealer carry a two-year warranty effective from the date of receiving the product. Machines sold for either commercial or industrial use have a one-year warranty. Wearable parts like throat plates, bandsaw guides, etc., have a ninety-day warranty.

Table A-1 Warranty Lengths

2 Year – New Machines Sold Through an Authorized Dealer
2 Year – Accessories Sold as Machine Options (excluding blades)
1 Year – Machines Sold for Commercial or Industrial Use
1 Year – Blades and Accessories outside or Machine Options
90 Days – Wearable Parts

Aside from being free of defects upon receiving, consumable parts, like cutters and abrasives, are not covered by this warranty unless otherwise stated by Laguna Tools®. These parts are designed to be used at the expense of the operator and are available for replacement or inventory purchase. The determination of a consumable part will be made on a case-by-case basis by Laguna Tools®.

Shipping Damage

Laguna Tools® is not responsible for damage or loss caused by a freight company or other circumstances not in the direct control of Laguna Tools®. All shipping-related claims for loss or damage to goods must be made to Laguna Tools® within twenty-four hours of delivery.

How to Receive Support

To file a warranty-claim please contact the warranty department at 1-800-234-1976. To receive customer service or technical support please contact the customer service or technical support please contact the customer service department at 1-800-332-4049. Parts, under warranty, are shipped at the expense of Laguna Tools® either by common carrier, FedEx ground services or similar method. Technical support to install replacement parts is primarily provided by phone, fax, email, or the Laguna Tools® Customer Service Support Website.



SUPERBRUSH SPECIFICATIONS

SUPERBRUSH 24

SUPERBRUSH 36

Warranty: Two years on parts and labor, limited;
 Manufacturer's warranties on conveyor belts and brush heads.

Dimensions:	Model 24: Height: 52" Width: 46"; Depth: 42" Model 36: Height: 52" Width: 58"; Depth: 42"
Dust Hood:	Model 24: Steel hood with 4" vacuum port, hinged back Model 36: Steel hood with two 4" vacuum ports, hinged back
Brush Speed:	Infinitely Variable, 400-1200 RPM.
Brush:	See Brushes & Supplies
Bearings:	1" sealed, permanently lubricated, ball.
Conveyor Bed:	Steel reinforced with four steel cross sections.
Conveyor Motor:	100 in-lbs. torque, direct-drive DC motor (1/17 HP). Infinitely variable from 0 to 15 feet per minute.
Conveyor Belt:	Polyurethane, rough top belt, with monofilament back, included. (Optional abrasive belt available.)
Stand Construction:	Zinc-plated steel, cast aluminum. Column tubes are centerless ground.
Drive Motor:	Both Models: 5HP, TEFC; 1,725 RPM; 60 HZ. Continuous Duty Single phase 208-230V
Minimum Stock Length:	All Models 10" without fixtures.
Height Adjustment:	All Models: 3/32" per turn; Depth Gauge with locking stop included.
Stock Thickness Capacity:	11" maximum, typical* with nylon brushes. 12" maximum, typical* with wire brushes. *can vary depending on specific brush types
Approximate Shipping Weight:	Model 24: 375 lbs. Model 36: 475 lbs.
Tension Rollers:	1 1/2" diameter, rubber covered infeed and outfeed rollers mounted under spring tension, fully adjustable.
Dust Collection:	Mandatory for all models.

SUPERBRUSH STAND ASSEMBLY PARTS LIST

Ref. Number	Description	Part Number			Qty./ Unit
		SB24	Both Models	SB36	
1	HANDLE, SWIVEL ASSY		31-0020		2
2	PIN, ROLL 3/16X1		20-0772		2
3	WASHER, 5/8 I.D. OILITE		50-3080		4
4	RING, 5/8 RETAINING		20-0752		1
5	SUPPORT, ADJUSTING SCREW		30-1112		8
6	SCREW, 1/4-20x1/2 SOCKET HEAD SET		10-2804		12
7	SCREW, INBOARD HEIGHT ADJ. FOLLOW		30-1211HR		1
8	CAP, 1" PLASTIC		80-4013		2
9	GEAR, MITER		20-1101		4
10	BUSHING, 1/2 I.D. OILITE ROUND		50-3107		4
11A	RPM, BRACKET		40-0670		1
11B	RPM, DECAL (NOT SHOWN)		94-1674		1
12	COLLAR, 1/2 I.D. SHAFT		20-1103		2
13	TUBE, COLUMN		30-3044		2
14	SCREW, RPM, MOTOR		30-1209		1
15	MOUNT, MOTOR		30-5103		1
16	NUT, 5/16-18 HEX		12-0003		6
17	WASHER, 5/16 SAE		11-0206		8
18	SCREW, 5/16-18x3/4 BRASS TIPPED SET		10-9906		6
19	BOLT, 3/8-16x1-1/2 HEX HEAD		10-9207		8
20	WASHER, 5/16 WROUGHT		11-9103		20
21	BOLT, 3/8-16x1 HEX HEAD		10-9205		12
22	NUT, 3/8-16 HEX		12-0005		8
23	LEVELING FOOT		20-0655		4
24	SCREW, OUTBOARD HEIGHT ADJ.		30-1212HR		1
25	NUT, 3/8-16 FLANGE LOCK		12-0209		24
26	BASE, COLUMN		30-1101		2
27	BASE SUPPORT BRACKET	40-0230		40-4241	1
28	NUT, 5/8-11HEAVY HEX LOCK		12-8015		1
29	SCREW, 1/2-13x1/2 SOCKET HEAD SET		10-8905		2
30	ROD, TRANSFER	30-1213		30-3117	1
31	SUPPORT BRUSH		30-5206		2
32	BOLT, 3/8-16x1 1/4 HEX		10-9206		4
33	SUPPORT, OUTBOARD TABLE		30-5204		1
34A	DEPTH GAUGE ROD		30-1260HR	ROD	1
34B	DECAL, SCALE		94-1654	SCALE	1
35	NUT, 9/16-12 HEX		12-0011		2
36	LEG		30-1102		4
37	KNOB, LOCKING W/ SET SCREW		81-3132		2
38	CAP, 3Y PLASTIC COLUMN TUBE		80-4015		2
39	SCREW, 5/16-18x3/8 SOCKET HEAD SET		10-2903		4
40	MOTOR MOUNT		40-0106		1
41	SUPPORT, INBOARD TABLE		30-5205		1
42	BRACKET, TABLE MOUNT	40-0025		40-0037	2
	CLIP, FRAME (NOT SHOWN)		72-6208		1
	BUSHING, 1/2 I.D. OILITE ROUND (NOT SHOWN)		50-3110		2

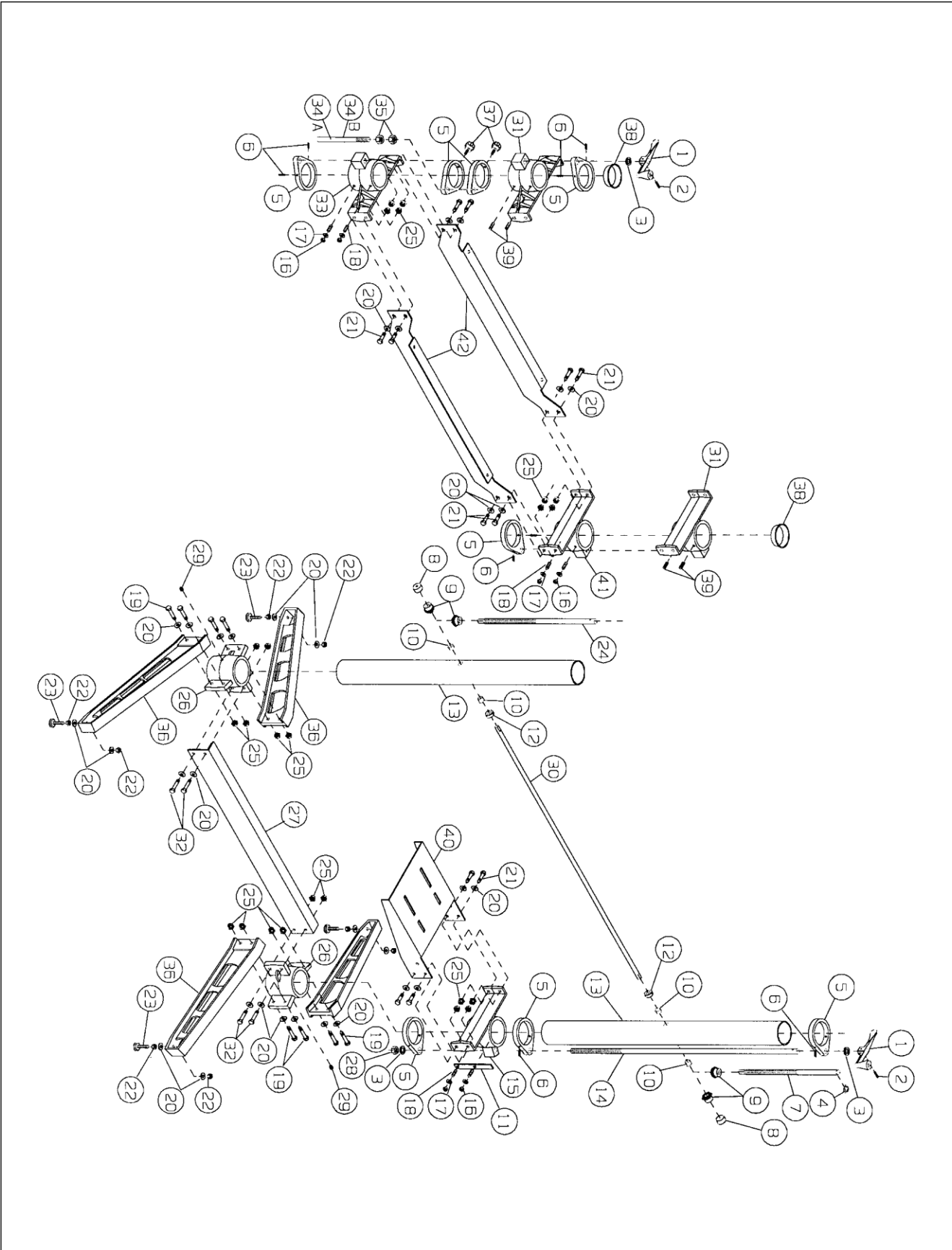

SUPERBRUSH HEAD ASSEMBLY PARTS LIST

Ref. Number	Description	Part Number			Qty./ Unit
		SB24	Both Models	SB36	
1	DUST COVER	40-0655		40-3655	1
2	HANDLE, DUST COVER		80-2841		1
3	BOLT, HEX 3/8-16X1		10-9205		8
4	WASHER, 5/16 SAE		11-0206		8
5	BRACKET, BEARING MOUNTING (see Fig. 25)		40-0613		2
6	BEARING		50-3086		2
7	SCREW, 1/4-20x1/4 SOCKET HEAD SET		10-8802		4
8	BOLT, 5/16-18x3/4 CARRIAGE		10-1203		8
9	PULLEY, 7" (TYPICAL)		50-0701		1
10	SCREW, 5/16-18x3/8 SOCKET HEAD SET		10-8903		1
11	NUT, 3/8-16 FLANGE LOCK		12-0209		8
12	KEY STOCK, 1/4x1/4x1 1/4		20-0764		1
13	SCREW, 1/4-20x1 3/4 ROUND HEAD MACHINE		10-3213		4
14	BRACKET, LEFT SUSPENSION		40-0323		2
15	SPRING, TENSION ROLLER		20-3284		4
16	BRACKET, RIGHT SUSPENSION		40-0326		2
17	BUSHING, 1/2 ID OILITE ROUND		50-3107		4
18	BRACKET, SUSPENSION BASE		40-0322		2
19	NUT, 1/4-20 RETAINING		20-1153		4
21	ROLLER TENSION	30-1218		30-3218	2
22	NUT, 5/16-18 FLANGE LOCK		12-0207		6
23	HINGE		40-0225		3
24	BRACKET, DUST COVER MOUNTING	40-0605		40-3605	1
25	SCREW, 1/4-20x1/2 ROUND HEAD MACH		10-3205		12
26	WASHER, 1/4 INTERNAL TOOTH LOCK		11-0504		12
27	SCREW, 8x1/2 SELF TAPPING		10-3904		2
28	WASHER, 1/4 SAE		11-0205		12
29	NUT, 1/4-20 HEX		12-0001		12
30	NUT 5/16-18 WING		12-9050		4
31	WASHER, 5/16 INTERNAL TOOTH LOCK		11-0505		4
32	BUMPER, DUST COVER		80-1065		2
33	GUARD, BELT COVER		40-0009		1
34	GUARD, BELT, PLATE		40-0010		1
35	GUARD, BELT LOWER		40-0011		1
36	GUARD, BELT, ANGLED		40-0012		1
37	NUT, RETAINING		20-1155		6
38	NUT, RETAINING		20-1157		4
39	SCREW, 10-24x3/8 SLOTTED HEX HEAD		10-3803		10
40	BRUSH		See page 35		1

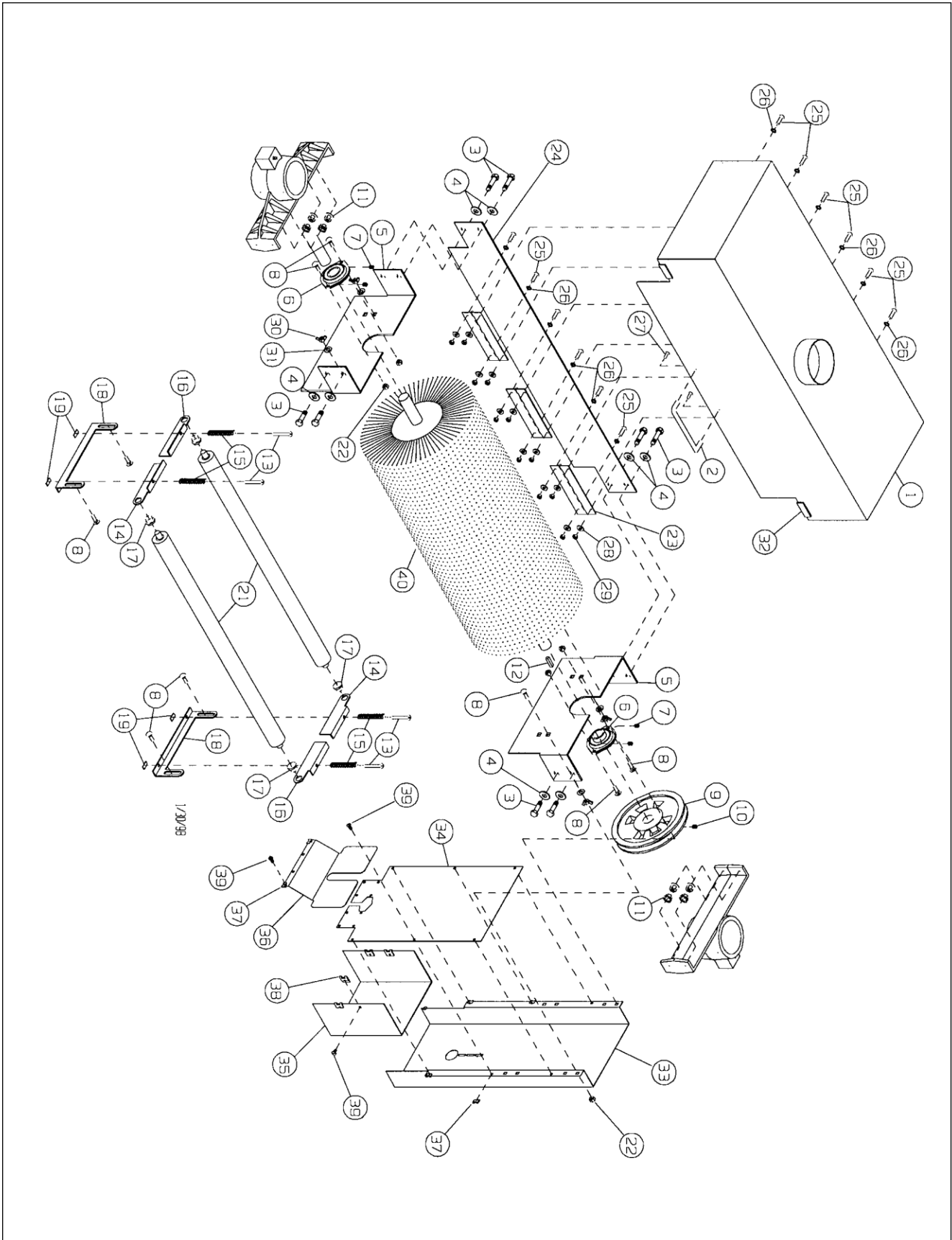

SUPERBRUSH CONVEYOR & MOTOR PARTS LIST					
Ref. Number	Description	Part Number			Qty./ Unit
		SB24	Both Models	SB36	
1	1/4"-20x1/2" ROUND HEAD MACH SCREW		10-3205		3
2	WASHER, 1/4 INTERNAL TOOTH LOCK		11-0504		3
3	SWITCH BRACKET		40-5005		1
4	SWITCH BOX		72-5400-2		1
5	ON/OFF SWITCH		72-5400-1		1
6	1/4"-20 HEX NUT		12-0001		3
7	LARGE STRAIN RELIEF		72-6104		4
8	CORD SET, SINGLE PHASE, 32"		72-5315		1
	CORD SET, THREE PHASE, 32"		72-5305		1
9	CONTROLLER, 180 V, VARIABLE SPEED INCLUDING KNOB, NUT AND DIAL PLATE		72-1260		1
10	SMALL STRAIN RELIEF		72-6102		1
11	FUSE HOLDER		72-6202		1
12	180-VOLT GEAR MOTOR		71-1171		1
13	Power Cord, NOT INCLUDED				
14	V-BELT		50-2029		1
15	RETAINING CLIP		72-6210		1
16	5/16"-18x3/8" SOCKET HEAD SET SCREW		10-2903		1
17	CORD SET, SINGLE PHASE, 66"		72-5315		1
	CORD SET, THREE PHASE, 66"		72-5305		1
18	KEY STOCK, 1/4x1 3/4		N/A		1
19	FUSE, 3/4 AMP		72-6201		1
21	PULLEY, DRIVE, VARIABLE SPEED		50-0704		1
22	#10-24 RETAINING NUT		20-1157		2
23	LOWER INNER BELT GUARD		40-1000		1
24	5/16"-18 FLANGED LOCK NUT		12-0207		4
25	3/8" WROUGHT WASHER		11-0104		2
26	MOTOR, 5 HP. TEFC, SINGLE PHASE		71-0502		1
	MOTOR, 5 HP. TEFC, THREE PHASE		71-1503		1
27	5/16"-18x3/4" CARRIAGE BOLT		10-1203		4
28	5/16"-18x1/2" HEX HEAD BOLT		10-9101		4
29	CONTROL HOUSING		40-5012		1
30	5/16"-18 RETAINING NUT		20-1159		4
31	SCREW, 5/16-18x1/4 SOCKET HEAD SET SCREW		10-8902		2
32	COUPLING (CONVEYOR)		30-3102		1
33	CONTROL BOX BASE BRACKET		40-4115		1
34	#10-24x3/8" SLOTTED HEX HEAD SCREW		10-3803		2
35	#10-24 RETAINING NUT		20-1155		2
36	BOTTOM COVER		40-4116		1
37	RIGHT SIDE RAIL		40-4106		1

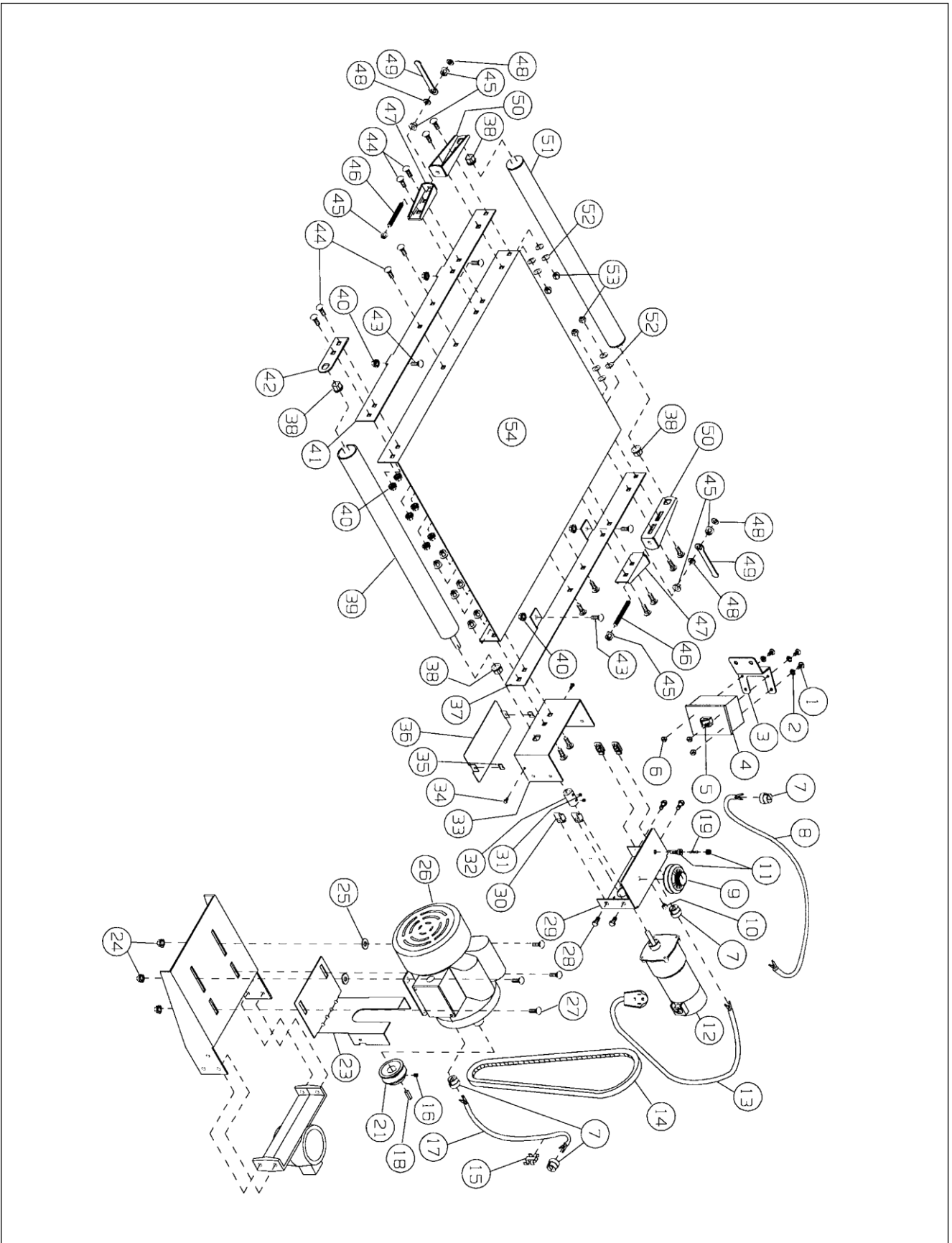

SUPERBRUSH CONVEYOR & MOTOR PARTS LIST (Con't.)

Ref. Number	Description	Part Number			Qty./ Unit
		SB24	Both Models	SB36	
38	1/2" I.D. SQUARE OILITE BUSHING		50-3109		4
39	RUBBER COVERED DRIVE ROLLER	30-3106		30-3107	1
40	3/8" FLANGED LOCK NUT		12-0209		16
41	LEFT SIDE RAIL		40-4105		1
42	ROLLER SUPPORT BRACKET		40-4109		1
43	3/8"-16x3/4" CARRIAGE BOLT		10-1301		4
44	3/8"-16x1" CARRIAGE BOLT		10-1302		16
45	5/16"-24 FLANGE NUT		12-0308		6
46	5/15"-24x3" STUD		30-1306		2
47	TAKE-UP BASE BRACKET		40-4107		2
48	5/16" SAE WASHER		11-0206		4
49	WRENCH		40-0375		2
50	TAKEUP SLIDE		40-4108		2
51	DRIVEN ROLLER	30-3103		30-3104	1
52	3/8" SPRING WASHER		20-1165		4
53	3/8"-16 NYLON INSERT LOCK NUT		12-8005		4
54	CONVEYOR BED	40-4101		40-4201	1
55	CONVEYOR BELT (NOT SHOWN)	61-1004		61-1007	1

BRUSHES & SUPPLY CHECKLIST

SUPERBRUSH OPTIONS

BRUSHES FOR THE SUPERBRUSH 24 AND SUPERBRUSH 36

DESCRIPTION	QTY.
60 Grit, Nylon/Silicon Carbide bristle, Open or Close wound	
80 Grit, Nylon/Silicon Carbide bristle, Open or Close wound	
120 Grit, Nylon/Silicon Carbide bristle, Open or Close wound	
180 Grit, Nylon/Silicon Carbide bristle, Open or Close wound	
220 Grit, Nylon/Silicon Carbide bristle, Open or Close wound	
320 Grit, Nylon/Silicon Carbide bristle, Open or Close wound	
520 Grit, Nylon/Silicon Carbide bristle, Open or Close wound	
Wire, Carbon Steel, Open or Close Wound	
Wire, Stainless Steel, Fineset	
Fladder style Brush combination, (Head Assembly).	
Fladder style Brush combination, (Abrasives only).	
Cloth polishing heads	

These are just a few types of the dozens of brushes available. Please contact Performax Products Inc. for a complete listing of brushes and brush material available or to run test samples of your specific application.

SUPPLIES:

ITEM #	DESCRIPTION	QTY.
98-0130	Caster Set: Heavy duty, roll & swivel lock.	
98-0025	Lowrider legs with 4 casters. Lowers machine on casters 5 1/2"	

CONVEYOR BELTS

TYPE 1: 100 grit abrasive surface with reinforced film backing.

TYPE 2: Polyurethane rib-textured surface with monofilament backing.

SUPERBRUSH 24	SUPERBRUSH 36		
60-0321	N/A	Type 1: Conveyor with 1" diameter Drive Roller.	
60-0324	60-0337	Type 1: Conveyor with 2" diameter Drive Roller.	
61-1001	N/A	Type 2: Conveyor with 1" diameter Drive Roller	
61-1004	61-1007	Type 2: Conveyor with 2" diameter Drive Roller.	

**For information on the SuperBrush and supplies
call 800-332-4049 or visit LagunaTools.com**

WARRANTY & REGISTRATION

Thank You!

Welcome to the Laguna Tools® group of discriminating machinery owners. We understand that you have a choice of where to purchase your machines and appreciate the confidence you have in the Laguna Tools® brand.

Through hands-on experience, Laguna Tools® is constantly working hard to make innovative, precision products. Products that inspire you to create works of art are a joy to operate and encourage your best work.

Laguna Tools®
Imagination, Innovation, and Invention at Work

Warranty & Registration

Every product sold is warranted to be free of manufacturer's defective workmanship, parts, and materials. For any questions about this produce, the intended use or what it was designed for, customer service, or replacement parts, please contact our customer service department:

Laguna Tools® Customer Service
744 Refuge Way, Grand Prairie, Texas 75050, USA
1-800-234-1976
customerservice@lagunatools.com
www.lagunatools.com/why/customer-service/
8AM. To 5PM PSF. Monday through Friday

For warranty claims or to report damage upon receiving-please reach out to our warranty department:

Laguna Tools® Warranty Service
744 Refuge Way, Grand Prairie, Texas 75050, USA
1-800-234-1976
customerservice@lagunatools.com
www.lagunatools.com/policies/warranty
8AM to 5PM PST, Monday through Friday

Registration

To prevent voiding this warranty, all products sold must be registered within thirty (30) days of receiving the product. Registering the product will enable the original purchaser to receive notifications about important product changes, receive customer service, and be able to file a warranty claim against defective workmanship, parts, or materials.



Who is Covered

The applicable warranty covers only the initial purchaser of the product from the date of receiving the product. To file such claims, the original purchaser must present the original receipt as proof of purchase.

What is Covered

The warranty covers any defects in the workmanship of all parts and materials that make up the machine unless otherwise specified. Any part determined by Laguna Tools® to have a defect will be repaired or replaced (and shipped), without charge. The defective item/part must be returned to Laguna Tools® with the complaint and proof of purchase in the original packaging that it was received in. In the event the item/part is determined to be not covered by this warranty, the customer will be responsible for the cost to replace the item/part and all related shipping charges

Warranty Limitations

This limited warranty does not apply to natural disasters, acts of terrorism, normal wear and tear, product failure due to lack of maintenance or cleaning, damage caused by accident, neglect, or lack-of inadequate dust collection. The warranty may be voided against proof of misuse/abuse, damage caused where repair or alterations have been made or attempted by others, using the product for purposes other than those described as intended use (unless with consent by Laguna Tools®), modification to the product, or use with an accessory that was not designed for the product. It is the responsibility of the user to understand basic machinery settings and procedures and to properly maintain the equipment in accordance with the standards provided in this manual.

Length of Warranty

All new machines and optional accessories sold through an authorized dealer carry a two-year warranty effective from the date of receiving the product. Machines sold for either commercial or industrial use have a one-year warranty. Wearable parts like throat plates, bandsaw guides, etc., have a ninety-day warranty.

Table A-1 Warranty Lengths

2 Year – New Machines Sold Through an Authorized Dealer
2 Year – Accessories Sold as Machine Options (excluding blades)
1 Year – Machines Sold for Commercial or Industrial Use
1 Year – Blades and Accessories outside of Machine Options
90 Days – Wearable Parts

Aside from being free of defects upon receiving, consumable parts, like cutters and abrasives, are not covered by this warranty unless otherwise stated by Laguna Tools®. These parts are designed to be used at the expense of the operator and are available for replacement or inventory purchase. The determination of a consumable part will be made on a case-by-case basis by Laguna Tools®.

Shipping Damage

Laguna Tools® is not responsible for damage or loss caused by a freight company or other circumstances not in the direct control of Laguna Tools®. All shipping-related claims for loss or damage to goods must be made to Laguna Tools® within twenty-four hours of delivery.

How to Receive Support

To file a warranty-claim please contact the warranty department at 1-800-234-1976. To receive customer service or technical support please contact the customer service or technical support please contact the customer service department at 1-800-332-4049. Parts, under warranty, are shipped at the expense of Laguna Tools® either by common carrier, FedEx ground services or similar method. Technical support to install replacement parts is primarily provided by phone, fax, email, or the Laguna Tools® Customer Service Support Website.

LAGUNA

CAUTION:

IMPORTANT SAFETY INFORMATION

FOR SAFE SANDING OPERATION, FOLLOW THESE GUIDELINES:

- **BECOME FAMILIAR WITH THE PROPER OPERATIONAL PROCEDURES FOR USING THIS MACHINE.**
- **ALWAYS BE SAFETY CONSCIOUS WHEN OPERATING THE MACHINE.**
- **ALWAYS WEAR EYE PROTECTION WHILE OPERATING THE SANDER.**
- **ALWAYS FEED STOCK AGAINST THE ROTATION OF THE BRUSH**
- **NEVER PLACE HANDS UNDER THE BRUSH OR DUST COVER.**
- **NEVER OPERATE SUPERBRUSH WITHOUT ITS DUST COVER OR PULLEYGUARD IN PLACE.**
- **KEEP HANDS AND CLOTHING AWAY FROM OPERATING BRUSH BELT AND PULLEYS.**
- **ALWAYS MAINTAIN CONTROL OF STOCK TO AVOID KICKBACK; KNOW HOW TO PREVENT IT.**
- **ALWAYS DISCONNECT ELECTRICAL POWER BEFORE PERFORMING ANY SERVICING OR ADJUSTMENT OF THE MACHINE.**
- **DO NOT MODIFY THIS MACHINE: MODIFICATIONS ARE DONE AT THE OWNER'S RISK AND ALSO WILL VOID THE MANUFACTURER'S WARRANTY.**
- **FOR CUSTOMER SERVICE AND QUESTIONS ABOUT THE OPERATION OR MAINTENANCE OF THIS MACHINE, PLEASE CALL YOUR AUTHORIZED SUPERMAX DEALER.**

Lagunatools.com
800-332-4049