

## Model 3135EC Easy-Close

DRAWER  
ADJUST

Full Extension Undermount

Vertical, horizontal, and front  
to back drawer front adjustment.

Optional Face Frame and Bottom Brackets

**APPLICATIONS:** For use  
in commercial and high end  
residential applications in  
drawers and shelves up to 30"  
wide. **This product is covered  
by U.S. and various foreign  
patents issued or pending.**

## 3135EC Easy-Close QUICK REFERENCE

Mounting: Undermount (Side)

Even Lengths: 12"-28", 15" & 21"

Load Rating: 100 lbs.\*

Easy-Close Feature

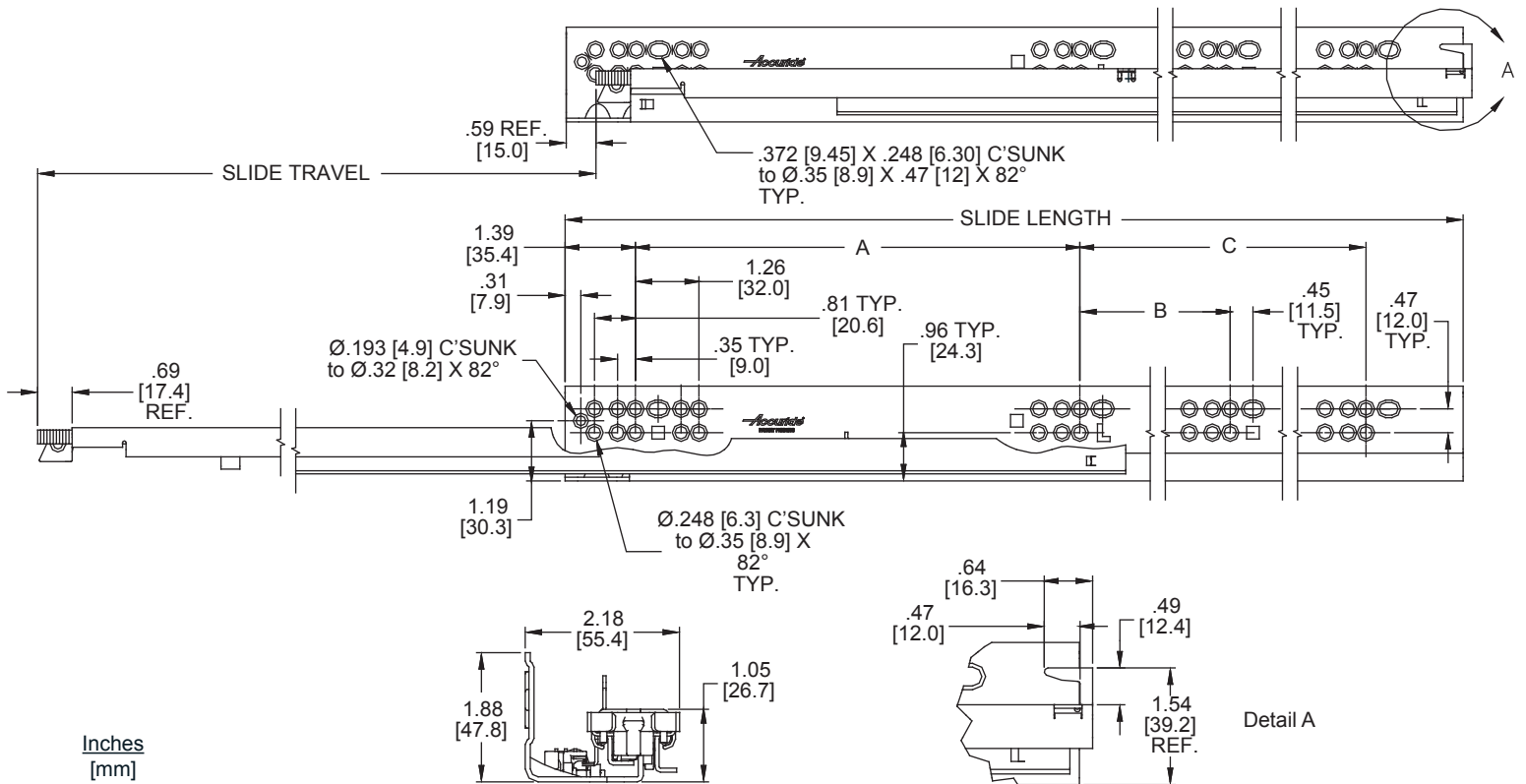

Inches  
[mm]

**Lengths** Even lengths 12"-28" [254 mm-711 mm],  
15" and 21" [381 mm, 533 mm]

**Height** 1.05" [26.8 mm]-Under drawer  
1.87" [47.5 mm]-Overall

**Travel** Full extension

**Slide Finish** Bright electro-zinc

**Load Rating** 100 lbs.\* [45.5 kg]

**Mounting** Undermount (Side), Optional hardware kits for face  
frame\*\* and bottom mount brackets.

**Features** Compatible with 1/2" [12.7 mm] to 5/8" [15.9 mm] drawer  
box thickness, 1/8" [3.2 mm] range of horizontal, vertical,  
front to back drawer front adjustment.

Part number	Slide Length	Slide Travel	A	B	C	Drawer Depths	Cabinet Depths
C 3135-12EC	12.00 [304.8]	11.50 [292.1]	5.04 [128.0]	3.78 [96.0]	-	12.00 [304.8]	12.63 [320.8] to 14.63 [371.6]
C 3135-14EC	14.00 [355.6]	13.50 [342.9]	5.04 [128.0]	3.78 [96.0]	-	14.00 [355.6]	14.63 [371.6] to 16.63 [422.4]
C 3135-15EC	15.00 [381.0]	14.50 [368.3]	5.04 [128.0]	3.78 [96.0]	-	15.00 [381.0]	15.63 [397.0] to 17.63 [447.8]
C 3135-16EC	16.00 [406.4]	15.50 [393.7]	5.04 [128.0]	7.56 [192.0]	-	16.00 [406.4]	16.63 [422.4] to 18.63 [473.2]
C 3135-18EC	18.00 [457.2]	17.50 [444.5]	5.04 [128.0]	7.56 [192.0]	-	18.00 [457.2]	18.63 [473.2] to 20.63 [524.0]
C 3135-20EC	20.00 [508.0]	19.50 [495.3]	8.82 [224.0]	7.56 [192.0]	-	20.00 [508.0]	20.63 [524.0] to 22.63 [574.8]
C 3135-21EC	21.00 [533.4]	20.50 [520.7]	8.82 [224.0]	7.56 [192.0]	-	21.00 [533.4]	21.63 [549.4] to 23.63 [600.2]
C 3135-22EC	22.00 [558.8]	21.50 [546.1]	8.82 [224.0]	10.08 [256.0]	-	22.00 [558.8]	22.63 [574.8] to 24.63 [625.6]
C 3135-24EC	24.00 [609.6]	23.50 [596.9]	8.82 [224.0]	10.08 [256.0]	-	24.00 [609.6]	24.63 [625.6] to 26.63 [676.4]
C 3135-26EC	26.00 [660.4]	25.50 [647.7]	8.82 [224.0]	10.08 [256.0]	13.86 [352.0]	26.00 [660.4]	26.63 [676.4] to 28.63 [727.2]
C 3135-28EC	28.00 [711.2]	27.50 [698.5]	8.82 [224.0]	10.08 [256.0]	13.86 [352.0]	28.00 [711.2]	28.63 [727.2] to 30.63 [778.0]

\* Load rating based on 18" slides installed in a 30" wide drawer cycled 50,000 times.

\*\* Face frame bracket is not available for 12"

**Drawer and Cabinet Build Requirements**

FIGURE 1

Build drawer and cabinet based on dimensions shown.

Drawer side thickness	5/8" [16]	19/32" [15]	9/16" [14]	1/2" [13]
For outside drawer width (deduct from inside cabinet width)	1/2" [13]	9/16" [14]	5/8" [16]	3/4" [19]
For inside drawer width (deduct from inside cabinet width)	1 3/4" [44.5]			

Maximum drawer height equals cabinet opening height minus 13/16" [20.6 mm].

Recommended drawer bottom inset 1/2" [12.7 mm] max.

FIGURE 2

Drawer depth equals slide length.

**Drawer Preparation**

FIGURE 3

Notch drawer back flush with drawer bottom to provide clearance for slides.

FIGURE 4

Pre-drill four holes for disconnect handle assemblies at 10° angle from bottom panel.\*

Pre-drill two holes for slide hooks.\*

\***Note:** The optional drill jig can be used to mark the notch and pre-drill holes on the drawer.

Figure 5

Install both disconnect levers to bottom of the drawer

**Note:** The levers should curve towards the center of the drawer.

Place disconnect handles against each inside corner of the drawer bottom and install with #6 pan head screws.

**Standard Lever Disconnect (vertical and horizontal)**

Figure 5A and 5B

For 1/2" drawer side thickness, install the included spacers along with the disconnect handles as shown in Figure 5A.

For drawers with bottom panels flush to the drawer front install lever disconnect vertically as shown in Figure 5B.

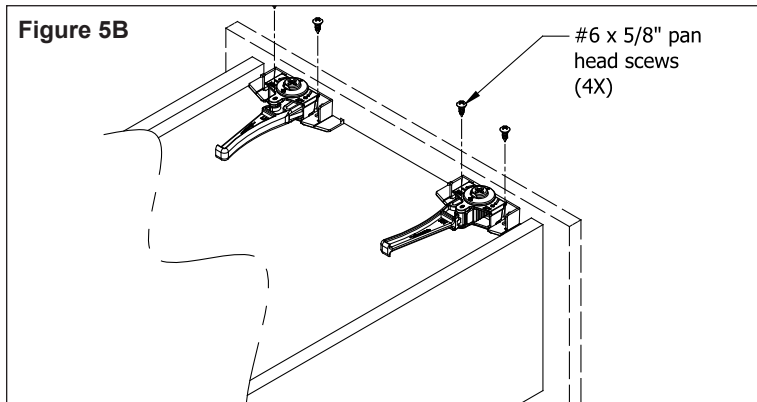
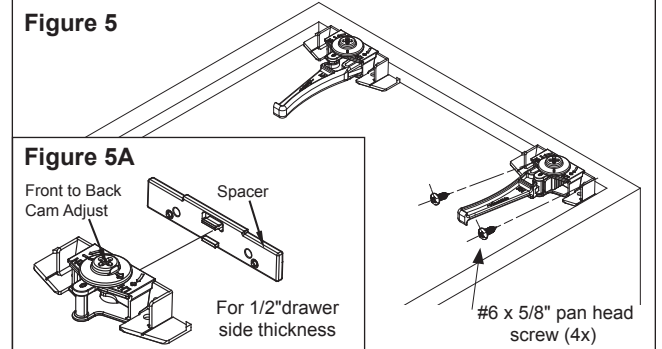
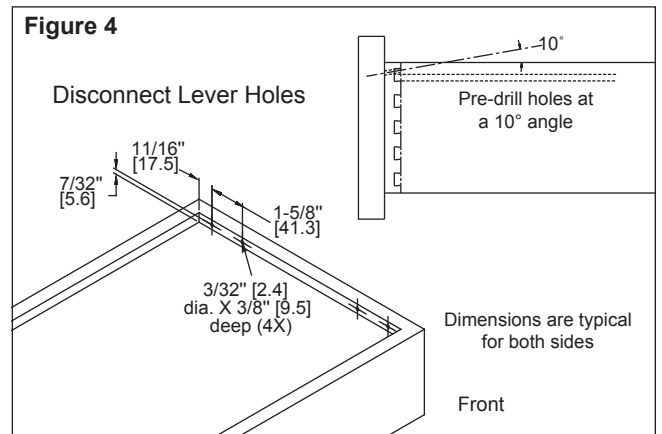
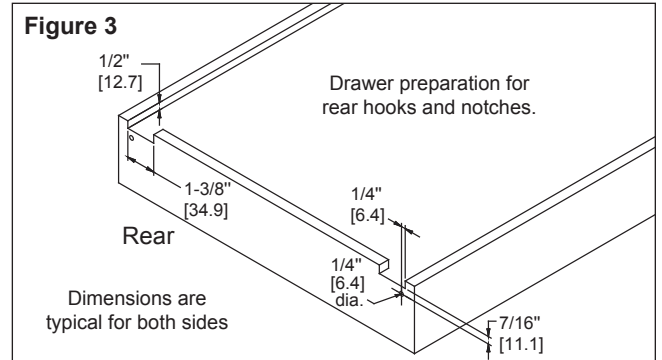
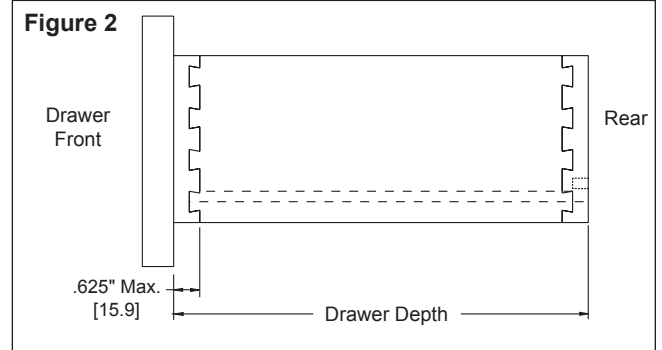
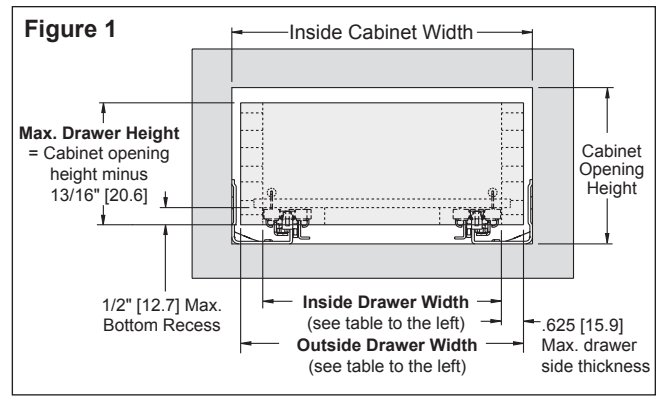

**Cabinet Member Installation**

Overlay Side mount or Frameless

FIGURE 6

If needed, pre-drill a hole 37 mm from cabinet front. The optional drill jig can be used to pre-drill this hole and/or pencil mark line in the 37 mm location from the cabinet front. For location of additional screw holes refer to the tabulated data on front page.

Install slides to cabinet wall with #8 x 5/8" flat head screws. Align slide member hole shown to pre-drilled hole 37 mm from front of cabinet to ensure proper gap. A minimum of 3 screws are recommended for each side. To finalize installation, see Fig. 9 instructions.

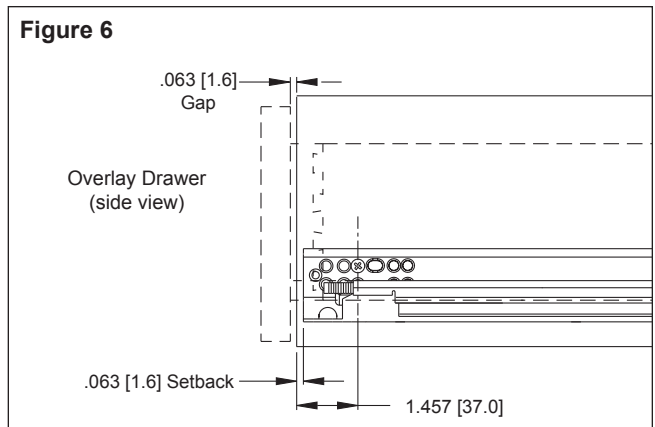

Inset Side mount or Frameless

FIGURE 7

Align slide member hole shown to pre-drilled hole 37 mm from front of cabinet for 5/8" drawer box thickness. Install slides to cabinet wall with #8 x 5/8" flat head screws.

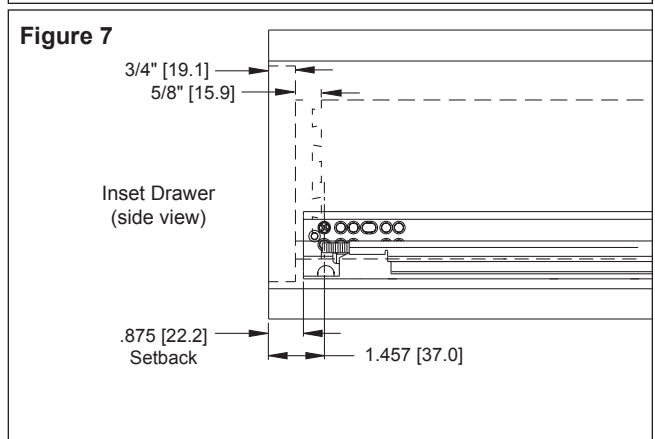

Overlay/Inset Face Frame

See the list of optional hardware kits on last page to select and purchase the appropriate face frame kit. Three separate kits are available to cover all face frame applications. Refer to the installation guide provided in each kit for mounting instructions.

Bottom Mount Bracket Option, 14" to 28" lengths

FIGURE 8

Purchase the optional bottom mount bracket kit 4180-0569-XE (see last page). Refer to the installation guide provided in the kit for detailed mounting instructions.

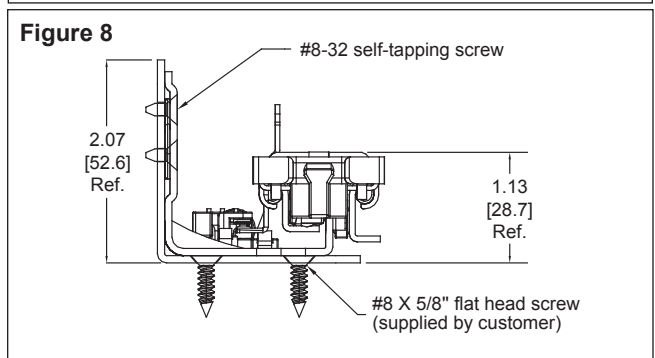

**Drawer Installation and Adjustments**

FIGURE 9

Connect the drawer to the slides. Lower the drawer onto the slides and push until the levers lock onto the front of the slides. Continue to push until the drawer "ratchets" in completely. Check to ensure the rear hooks on the slide fit into the rear holes of the drawer. For face frame\*\* mounting, pull drawer to the extended position. Adjust the rear bracket vertically and horizontally to ensure the mounted drawer is square to the cabinet and the slides are parallel to each other. Secure the rear bracket to the cabinet rear wall with additional #8 x 5/8" pan head screws.

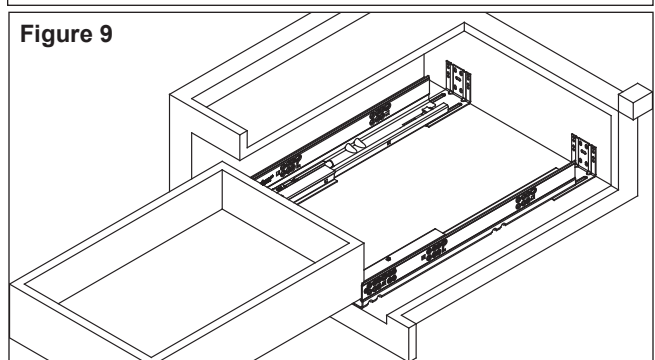
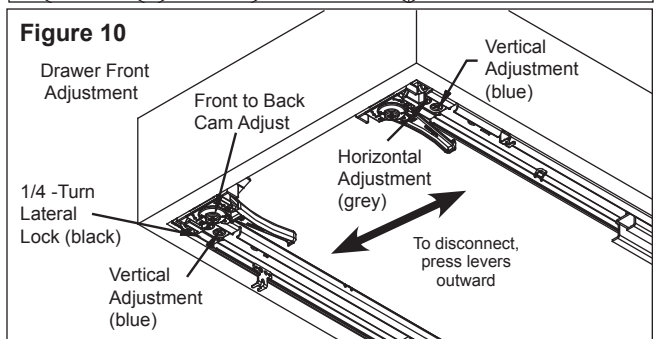

FIGURE 10

**NOTE: Prior to making any drawer adjustment, loosen the black 1/4-turn lateral lock by turning it counterclockwise.**

Adjust horizontal and vertical position of drawer front by rotating the corresponding cam with a #2 Phillips or #2 pozi screwdriver. To secure drawer front position, lock the drawer position by turning the 1/4-turn lateral lock clockwise 1/4-turn.



Complete your order for Accuride model 3135EC by specifying the following:

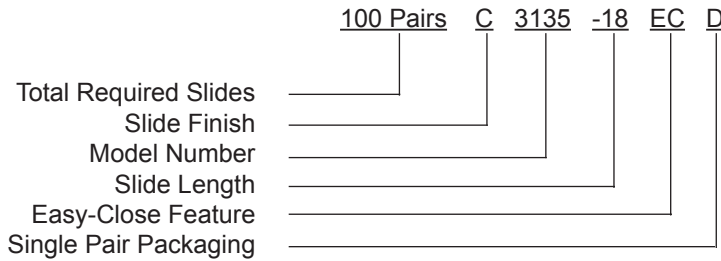

**Optional Hardware Kits**

**Rear Face Frame Brackets\*\***

Face frame brackets are ordered as a kit, or in bulk. To order the kit, specify part number 4180-0656-XE. Each kit contains 2 rear brackets and mounting hardware in a polybag.

To order in bulk, specify part number 4180-0655-XE. Brackets are packaged 120 each per box.

**Inset Face Frame Brackets**

Inset face frame brackets are ordered as a kit, or in bulk. To order the kit, specify part number 4180-0604-XE. Each kit contains 2 inset brackets and 2 each #8-32 flat head screws in a polybag.

To order in bulk, specify part number 4180-0620-XE. Brackets are packaged 120 each per box.

**Bottom Inset Face Frame Brackets**

Bottom inset face frame brackets are ordered as a kit. To order the kit, specify part number 4180-0605-XE. Each kit contains 2 brackets and 2 each #8-32 flat head screws in a polybag.

**Bottom Mount Brackets (14"- 28" only)**

Bottom mount brackets are ordered as a kit. Mounting screws are not included. To order the kit, specify part number 4180-0569-XE. Each kit contains 4 bottom mount brackets, self-tapping screws and one installation sheet.

**Drill Jig (P/N 4180-0568-XE)**

The jig provides hole locations for drawer hook, front face frame hole, disconnect lever, and front cabinet holes.

**Tool Kit (P/N 4180-0603-XE)**

This kit consists of various handy tools that can assist with the drilling and installation.

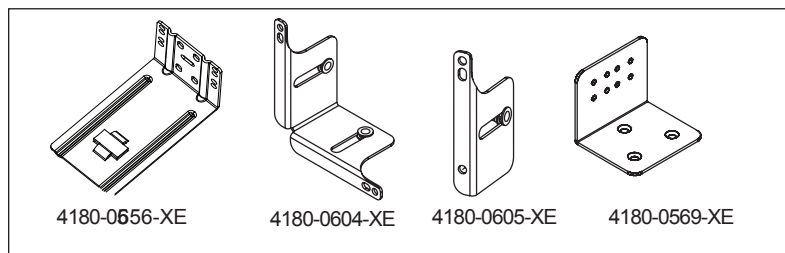

Slide Members: Cold rolled steel  
 Ball Retainers: Polymer  
 Ball Bearings: Carburized steel and polymer  
 Rollers: Polymer  
 RoHs Compliant

**NOTE:** Specifications, materials, prices, terms, and delivery are subject to change without notice.

**Packaging Options**

**Distributor (D) Pack**

All lengths are packaged 1 pair per box. Box includes one pair of slides with 6 ea. #8 x 5/8" Phillips flat head screws (for slides), 2 ea. standard horizontal disconnect levers, and 4 ea. #6 x 5/8" phillips pan head screws (for levers).

**Bulk (P) Pack**

Lengths 12"-24" packaged 6 pair per box  
 Lengths 26"-28" packaged 4 pair per box

A separate polybag containing 36 ea. #8 x 5/8" Phillips flat head screws are included. Disconnect levers and screws for lever installation are ordered separately.

**Disconnect Lever Packaging Options**

**Standard Horizontal and Vertical Lever Disconnect (P/N 4180-0747)**

One pair individually packaged with 4 ea. #6 x 5/8" Phillips pan head type 17s in a polybag.

**Standard Horizontal and Vertical Lever Disconnect, Bulk (P/N 4180-0748)**

Left hand and right hand levers are packaged separately. 60 levers per box. Each box contains 120 mounting screws in a polybag.



Accuride International Inc.

12311 Shoemaker Avenue Manufacturing, Engineering, and Sales  
 Santa Fe Springs, CA 90670 United States • Germany • Japan •  
 TEL (562) 903-0200 Mexico • United Kingdom • China  
 FAX (562) 903-0208

For the most current technical information visit [www.accuride.com](http://www.accuride.com)

**⚠ WARNING:** This product can expose you to chemicals including nickel, which is known to the State of California to cause cancer and birth defects or other reproductive harm. For more information go to [www.P65Warnings.ca.gov](http://www.P65Warnings.ca.gov).