



# Operating Instructions and Parts Manual

## Oscillating Edge Sander

Model OES-689-BLK



**JET**  
427 New Sanford Road  
La Vergne, TN 37086  
Ph.: 800-274-6848  
[www.jettools.com](http://www.jettools.com)

**Part No. M-JT1-1372**  
Edition 2 10/2024  
Copyright ©2024 JET

# 1.0 Warranty and Service

JET® warrants every product it sells against manufacturers' defects. If one of our tools needs service or repair, please contact Technical Service by calling 1-800-274-6846, 8AM to 5PM CST, Monday through Friday.

### Warranty Period

The general warranty lasts for the time period specified in the literature included with your product or on the official JET branded website.

- JET products carry a limited warranty which varies in duration based upon the product. (See chart below)
- Accessories carry a limited warranty of one year from the date of receipt.
- Consumable items are defined as expendable parts or accessories expected to become inoperable within a reasonable amount of use and are covered by a 90 day limited warranty against manufacturer's defects.

### Who is Covered

This warranty covers only the initial purchaser of the product from the date of delivery.

### What is Covered

This warranty covers any defects in workmanship or materials subject to the limitations stated below. This warranty does not cover failures due directly or indirectly to misuse, abuse, negligence or accidents, normal wear-and-tear, improper repair, alterations or lack of maintenance. JET woodworking machinery is designed to be used with Wood. Use of these machines in the processing of metal, plastics, or other materials outside recommended guidelines may void the warranty. The exceptions are acrylics and other natural items that are made specifically for wood turning.

### Warranty Limitations

Woodworking products with a Five Year Warranty that are used for commercial or industrial purposes default to a Two Year Warranty. Please contact Technical Service at 1-800-274-6846 for further clarification.

### How to Get Technical Support

Please contact Technical Service by calling 1-800-274-6846. **Please note that you will be asked to provide proof of initial purchase when calling.** If a product requires further inspection, the Technical Service representative will explain and assist with any additional action needed. JET has Authorized Service Centers located throughout the United States. For the name of an Authorized Service Center in your area call 1-800-274-6846 or use the Service Center Locator on the JET website.

### More Information

JET is constantly adding new products. For complete, up-to-date product information, check with your local distributor or visit the JET website.

### How State Law Applies

This warranty gives you specific legal rights, subject to applicable state law.

### Limitations on This Warranty

JET LIMITS ALL IMPLIED WARRANTIES TO THE PERIOD OF THE LIMITED WARRANTY FOR EACH PRODUCT. EXCEPT AS STATED HEREIN, ANY IMPLIED WARRANTIES OF MERCHANTABILITY AND FITNESS FOR A PARTICULAR PURPOSE ARE EXCLUDED. SOME STATES DO NOT ALLOW LIMITATIONS ON HOW LONG AN IMPLIED WARRANTY LASTS, SO THE ABOVE LIMITATION MAY NOT APPLY TO YOU.

JET SHALL IN NO EVENT BE LIABLE FOR DEATH, INJURIES TO PERSONS OR PROPERTY, OR FOR INCIDENTAL, CONTINGENT, SPECIAL, OR CONSEQUENTIAL DAMAGES ARISING FROM THE USE OF OUR PRODUCTS. SOME STATES DO NOT ALLOW THE EXCLUSION OR LIMITATION OF INCIDENTAL OR CONSEQUENTIAL DAMAGES, SO THE ABOVE LIMITATION OR EXCLUSION MAY NOT APPLY TO YOU.

JET sells through distributors only. The specifications listed in JET printed materials and on official JET website are given as general information and are not binding. JET reserves the right to effect at any time, without prior notice, those alterations to parts, fittings, and accessory equipment which they may deem necessary for any reason whatsoever. JET® branded products are not sold in Canada by JPW Industries, Inc.

### Product Listing with Warranty Period

|  |
|--|
| 90 Days – Parts; Consumable items  |
| 1 Year – Motors; Machine Accessories   |
| 2 Year – Metalworking Machinery; Electric Hoists, Electric Hoist Accessories; Woodworking Machinery used for industrial or commercial purposes                             |
| 5 Year – Woodworking Machinery   |
| Limited Lifetime – JET Parallel clamps; VOLT Series Electric Hoists; Manual Hoists; Manual Hoist Accessories; Shop Tools; Warehouse & Dock products; Hand Tools; Air Tools |

NOTE: JET is a division of JPW Industries, Inc. References in this document to JET also apply to JPW Industries, Inc., or any of its successors in interest to the JET brand.

## 2.0 Table of Contents

| Section   | Page |
|---|------|
| 1.0 Warranty and Service.....                                 | 2    |
| 2.0 Table of Contents.....                                    | 3    |
| 3.0 Safety Warnings.....                                      | 4    |
| 4.0 About this Manual.....                                    | 5    |
| 5.0 Specifications.....                                       | 6    |
| 6.0 Features.....   | 7    |
| 7.0 Setup and Assembly.....                                   | 8    |
| 7.1 Shipping Contents.....                                    | 8    |
| 7.2 Assembly.....   | 9    |
| 7.3 Dust Collection.....                                      | 11   |
| 8.0 Electrical Connections.....                               | 12   |
| 8.1 Grounding Instructions.....                               | 12   |
| 8.2 115 Volt Operation.....                                   | 12   |
| 8.3 230 Volt Operation.....                                   | 12   |
| 8.4 Extension Cords.....                                      | 13   |
| 9.0 Adjustments.....  | 14   |
| 9.1 Sanding Platen Angle and Table Adjustment.....            | 14   |
| 9.2 Changing the Sanding Belt.....                            | 14   |
| 9.3 Belt Tracking Adjustment.....                             | 15   |
| 9.4 Motor Mount Tracking Adjustment.....                      | 15   |
| 9.5 Table Adjustment.....                                     | 16   |
| 9.6 End Guard.....  | 16   |
| 9.7 Extension Table.....                                      | 16   |
| 10.0 Operation.....   | 17   |
| 10.1 Horizontal Sanding.....                                  | 17   |
| 10.2 Vertical Sanding.....                                    | 17   |
| 10.3 Contour Sanding.....                                     | 17   |
| 11.0 Maintenance.....   | 18   |
| 11.1 Lubrication.....   | 18   |
| 12.0 Troubleshooting.....                                     | 18   |
| 13.0 Replacement Parts.....                                   | 20   |
| 13.1.1 OES-689-BLK Cabinet Assembly – Exploded View.....      | 21   |
| 13.1.2 OES-689-BLK Main Machine Assembly – Exploded View..... | 22   |
| 13.1.3 OES-689-BLK Table Assembly – Exploded View.....        | 23   |
| 13.2 OES-689-BLK Oscillating Edge Sander – Parts List.....    | 24   |
| 14.0 Electrical Connections.....                              | 27   |
| 14.1 Electrical Connections for 1.75HP, 1PH, 115V.....        | 27   |
| 14.2 Electrical Connections for 1.75HP, 1PH, 230V.....        | 27   |



### 3.0 Safety Warnings

1. Read and understand the entire owner's manual before attempting assembly or operation.
2. Read and understand the warnings posted on the machine and in this manual. Failure to comply with all of these warnings may cause serious injury.
3. Replace the warning labels if they become obscured or removed.
4. This oscillating edge sander is designed and intended for use by properly trained and experienced personnel only. If you are not familiar with the proper and safe operation of a sander, do not use until proper training and knowledge have been obtained.
5. Do not use this sander for anything other than its intended use. If used for other purposes, JET disclaims any real or implied warranty and holds itself harmless from any injury that may result from that use.
6. This machine has an industrial-grade low-friction corrosion-resistant coating we call JET Black. This coating is on the table and extension table. While the JET Black coating is durable, it can be damaged if metal or other hard and/or sharp objects strike, gouge, or scratch the surface. Significant damage to the coating may affect its performance.
7. Always wear approved safety glasses/face shields while using this sander. Everyday eyeglasses only have impact resistant lenses; they are *not* safety glasses.
8. Before operating this sander, remove necktie, rings, watches and other jewelry, and roll sleeves up past the elbows. Do not wear loose clothing. Confine long hair. Non-slip footwear or anti-skid floor strips are recommended. Do not wear gloves.
9. Wear ear protectors (plugs or muffs) if noise exceeds safe levels.
10. Do not operate this machine while tired or under the influence of drugs, alcohol, or any medication.
11. Make certain switch is in OFF position before connecting machine to power supply.
12. Make certain machine is properly grounded.
13. Make all machine adjustments or maintenance with machine unplugged from the power source.
14. Remove adjusting keys and wrenches. Form a habit of checking to see that keys and adjusting wrenches are removed from the machine before turning it on.
15. Keep safety guards in place at all times when machine is in use. If removed for maintenance purposes, use extreme caution and replace the guards immediately after completion of maintenance.
16. Check damaged parts. Before further use of the machine, a guard or other part that is damaged should be carefully checked to determine that it will operate properly and perform its intended function. Check for alignment of moving parts, binding of moving parts, breakage of parts, mounting and any other conditions that may affect its operation. A guard or other part that is damaged should be properly repaired or replaced.
17. Provide for adequate space surrounding work area and non-glare, overhead lighting.
18. Keep work area clean. Keep floor around machine clean and free of scrap material, oil, and grease. Dirty and cluttered floors invite accidents.
19. Keep children away. Keep visitors a safe distance from the work area.
20. Make your workshop child-proof with padlocks, master switches, or by removing starter keys.
21. Give your work undivided attention. Looking around, carrying on a conversation, and "horse-play" are careless acts that can result in serious injury.
22. Maintain a balanced stance at all times so that you do not fall into the sanding belt or other moving parts. Do not overreach or use excessive force to perform any machine operation.
23. Use the right tool at the correct speed and feed rate. Do not force the tool or an attachment to do a job for which it was not designed. The tool will do the job better and more safely at the rate for which it was designed.
24. Use recommended accessories; improper accessories may be hazardous.
25. Maintain control of workpiece at all times. Make sure the work piece is stabilized during operation. Firmly hold workpiece with both hands and down against table while sanding. Use the miter gauge and backstop whenever possible. Maintain 1/16" maximum clearance between table and sanding belt.
26. Do not place fingers, hands, or other body parts near, or in contact with, the sanding belt during operation.
27. Use proper extension cord. Make sure your extension cord is in good condition. When using an extension cord, be sure to use one heavy enough to carry the current your product will draw. An undersized cord will cause a drop in line voltage resulting in loss of power and

overheating. Table 1 of Section 8.4 *Extension Cords* shows correct size to use depending on cord length and nameplate ampere rating. If in doubt, use the next heavier gage. The smaller the gage number, the heavier the cord.

28. Do not stand on the machine. Serious injury could occur if the machine tips over.
29. Never leave the machine running unattended. Turn the power off and do not leave the machine until it comes to a complete stop.
30. Remove loose items and unnecessary work pieces from the area before starting the machine.
31. Do not use in dangerous environment. Don't use power tools in damp or wet locations or expose them to rain. Keep work area well lighted.
32. This sander is intended to be used with wood and wood products only. Use of this sander and

a dust collector with metal products is a potential fire hazard.

33. Do not sand workpieces that are too small to be safely supported.
34. Allow machine to reach operating speed before beginning to sand.
35. Do not operate this sander with a damaged drive wheel, idler wheel, or sanding belt.
36. Maintain this machine with care. Follow instructions in Section 13.0 *Maintenance*.
37. Turn off the machine and disconnect from power source before cleaning or servicing. Use a brush or compressed air to remove chips or debris — do not use your hands.

**Familiarize yourself with the following safety notices used in this manual:**



This means that if precautions are not heeded, it may result in minor injury and/or possible machine damage.



This means that if precautions are not heeded, it may result in serious, or possibly even fatal, injury.

## SAVE THESE INSTRUCTIONS

### 4.0 About this Manual

This manual is provided by JET covering the safe operation and maintenance procedures for a JET Model OES-689-BLK Sander. This manual contains instructions on installation, safety precautions, general operating procedures, maintenance instructions and parts breakdown. This machine has been designed and constructed to provide consistent, long-term operation if used in accordance with instructions set forth in this manual. If there are any questions or comments, please contact either your local supplier or JET. You can also reach us at our web site: [www.jettools.com](http://www.jettools.com).

Register your product using the mail-in card provided or register online:

[www.jettools.com/product-registration](http://www.jettools.com/product-registration)

**To quickly reach the product registration webpage, scan the QR code below.**



**Read and understand the entire contents of this manual before attempting assembly or operation! Failure to comply may cause serious injury!**

## 5.0 Specifications

|                                       |  |
|---------------------------------------|--|
| Model .....                           | OES-689-BLK  |
| Stock Number .....                    | JT1-1372   |
| Fence (H x L) .....                   | 4" x 24"   |
| Abrasive Belt Size (W x L) .....      | 6" x 89"   |
| Dust Chute Diameter .....             | 4"   |
| Table Size (L x W x H) .....          | 29-1/2" x 10" x 1-3/8"                             |
| Table Vertical Travel .....           | 3-3/16"  |
| Belt Tilt .....                       | 0-90°  |
| Table to Belt Gap .....               | 0.18" to 0.22"                                     |
| Extension Table Size .....            | 9-7/8" x 11-7/8"                                   |
| Extension Table Vertical Travel ..... | 5"   |
| Motor .....                           | TEFC 1.75 HP, 115/230V (prewired 115V), 60Hz, 1 PH |
| Full Load Amps .....                  | 14.5A / 7.2A                                       |
| Starting Amps .....                   | 52A / 33A  |
| Running Amps .....                    | 6.0A / 3.17A                                       |
| Motor Speed .....                     | 3450 RPM   |
| Belt Speed .....                      | 20.33 m/s, 4000 FPM, Belt Speed 540 RPM            |
| Oscillation Stroke .....              | 1/4"   |
| Oscillations per Minute .....         | 106  |
| Overall Dimensions with Cabinet ..... | 51-3/16" x 31-1/2" x 49-1/4"                       |
| Base Footprint .....                  | 20-5/8" x 16"                                      |
| Cabinet Dimensions .....              | 20-5/8" x 16" x 22-1/2"                            |
| Net Weight, approximate .....         | 280 lbs.   |
| Shipping Weight, approximate .....    | 352 lbs.   |

The above specifications were current at the time this manual was published, but because of our policy of continuous improvement, JET reserves the right to change specifications at any time and without prior notice, without incurring obligations.

# 6.0 Features



Figure 6-1

## 7.0 Setup and Assembly

**CAUTION** This machine has an industrial-grade low-friction corrosion-resistant coating on the table and extension table. While the coating is durable, it can be damaged if metal or other hard and/or sharp objects strike, gouge, or scratch the surface. Significant damage to the coating may affect its performance. Use care when unpacking and locating the machine and during all setup and assembly procedures.

Carefully unpack the sander and any loose items from the wood crate and inspect for damage. Any damage should be reported immediately to your distributor and shipping agent. Do not discard any shipping material until the sander is assembled and running properly. Before proceeding further, read your manual thoroughly to familiarize yourself with proper assembly, maintenance and safety procedures.

Compare the contents of your container with the following parts list to make sure all parts are included. Missing parts, if any, should be reported to your distributor.

### 7.1 Shipping Contents

The items below are shipped with the sander.

#### Cabinet Contents (Figure 7-1):

- 1 – Door with Latch – A
- 1 – Cabinet Front Panel – B
- 2 – Cabinet Side Panels – C
- 1 – Cabinet Rear Panel – D
- 1 – Cabinet Shelf – E
- 4 – Sanding Belt Hooks – F

#### Hardware Contents (Figure 7-2):

- 4 – Rubber Feet with M10 Hex Nuts – G
- 4 – M8x16 Hex Cap Screws – H
- 4 – 8mm Flat Washers - H
- 4 – M8x25 Hex Cap Screws – I
- 4 – 8mm Flat Washers - I
- 4 – 8mm Lock Washers – I
- 8 – M8x16 Carriage Bolts – J
- 8 – 8mm Flat Washers - J
- 8 – M8 Hex Nut – J
- 8 – M5x10 Socket Head Button Screw – K
- 8 – 5mm Flat Washers – K

#### Other Contents (Figure 7-3):

- 1 – Belt Tensioning Handle – L
- 5 – Hex Wrenches, 2.5, 3, 4, 5, 6mm – M
- 1 – Door Latch Keys – N
- 1 – Miter Gauge – O
- 1 – Belt Tracking Adjustment Tool – P
- 1 – Extension Table Assembly – Q

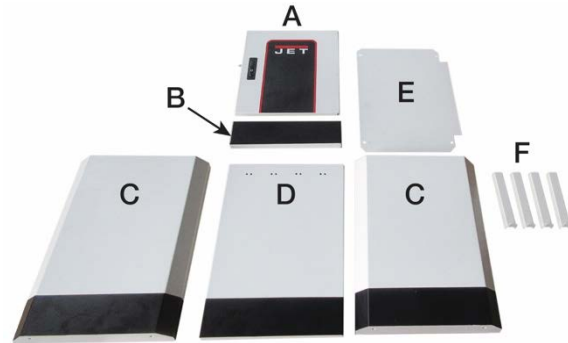

Figure 7-1

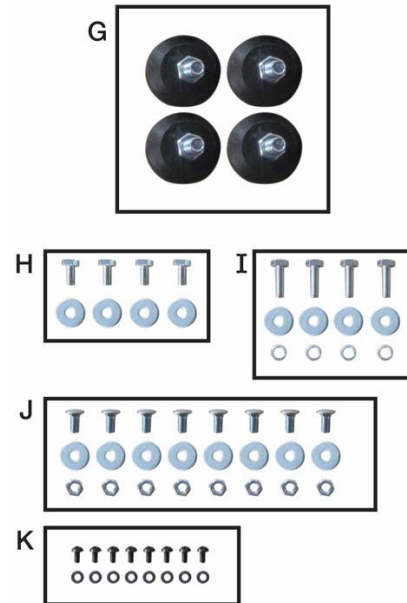

Figure 7-2

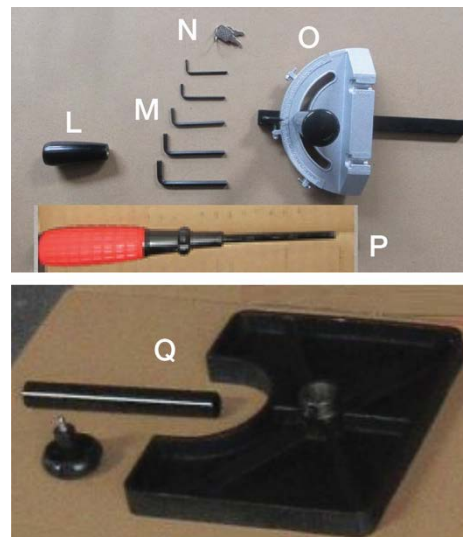

Figure 7-3



## 7.2 Assembly

**CAUTION** This machine has an industrial-grade low-friction corrosion-resistant coating on the table and extension table. While the coating is durable, it can be damaged if metal or other hard and/or sharp objects strike, gouge, or scratch the surface. Significant damage to the coating may affect its performance. Use care when installing and assembling the machine.

### 7.2.1 Cabinet Assembly

Refer to Figure 7-4:

1. Remove all contents from the shipping container.
2. Clean all rust protected surfaces with a mild solvent. Do not use paint or lacquer thinner, gasoline, or mineral spirits; these will damage painted surfaces.
3. Make sure M10 hex nut (B) is attached to the four rubber feet (A). Attach rubber feet to the bottoms of the side panels (C).
4. Attach side panels (C) to back panel (D) using four M8x16 carriage bolts, 8mm flat washers, and M8 hex nuts. Only hand tighten the bolts and nuts.
5. Attach the side panels (C) to the front panel (E) using four M8x16 carriage bolts, 8mm flat washers, and M8 hex nuts. Only hand tighten the bolts and nuts. Make sure the door hinge mounting hole on the front panel is facing up.
6. Mount the bottom panel (F) to the inside of the cabinet using four M8x16 hex cap screws and 8mm flat washers. Only hand tighten the screws.
7. Attach four sanding belt hooks (G) to back panel (D) using eight M5x10 socket head button screws and 5mm flat washers.
8. Firmly tighten all hardware. Make sure cabinet is sitting evenly on a level surface before tightening hardware.

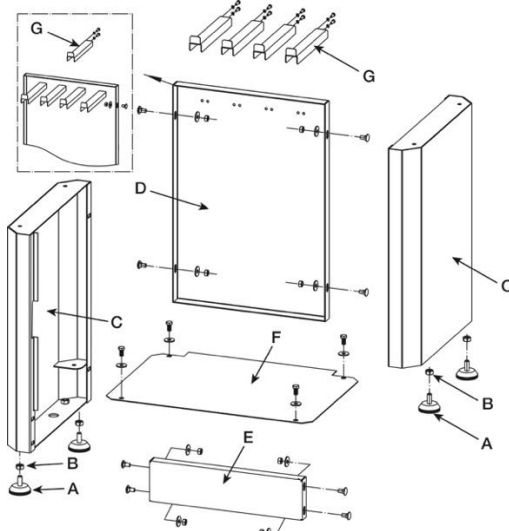

Figure 7-4

### 7.2.2 Installing Table and Motor Unit to Cabinet

**WARNING** The sanding table assembly is heavy! Use great care and adequate resources when lifting the assembly out of the crate and onto the cabinet! Failure to comply may cause serious injury and/or damage to the sander and/or property!

Refer to Figure 7-5:

1. With the aid of another person, carefully lift the sanding table assembly (A) from the shipping container. Place sanding table assembly onto the cabinet assembly (B).
2. Line up threaded holes in the sanding table assembly (C) with the holes in the cabinet (D).
3. Attach the sanding table assembly to cabinet using four M8x25 hex cap screws, M8 lock washers, and 8mm flat washers. Tighten firmly.

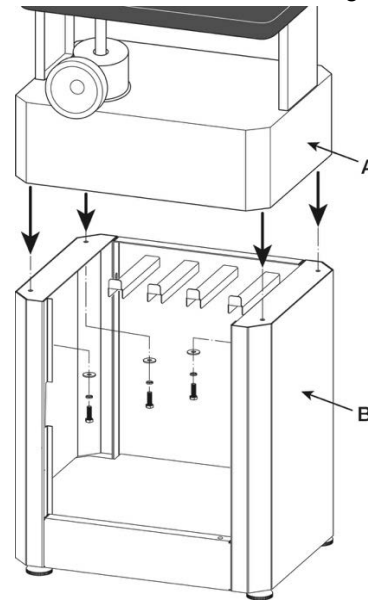

Figure 7-5

### 7.2.3 Installing Cabinet Door

Refer to Figure 7-6:

1. Attach cabinet door. Insert the lower hinge axle into the hole on top edge of front panel. Press down the spring-loaded upper hinge axle and insert it into the hole at the bottom of the sander base. Allow spring-loaded upper hinge axle to spring up into hole.

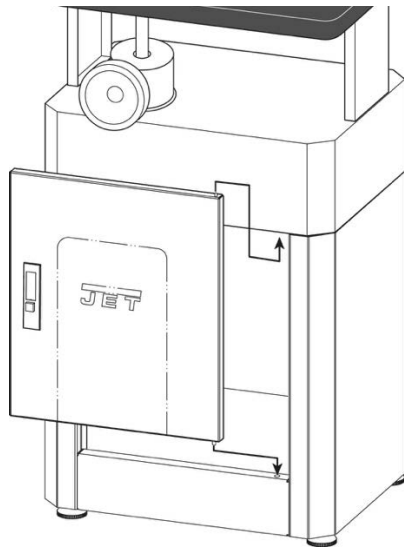

Figure 7-6

### 7.2.4 Moving Platen to Vertical Position

Refer to Figures 7-7 & 7-8:

1. The sanding platen (A, Figure 7-7) is presently in the horizontal (flat) position. Loosen locking handle (B, Figure 7-7).
2. Using the tilting handle (C, Figure 7-7), rotate sanding platen to the vertical position (see Figure 7-8).
3. Tighten the locking handle (B, Figure 7-8) to lock the platen assembly in place.

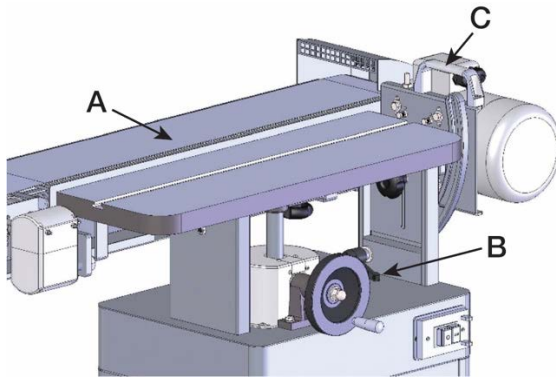

Figure 7-7

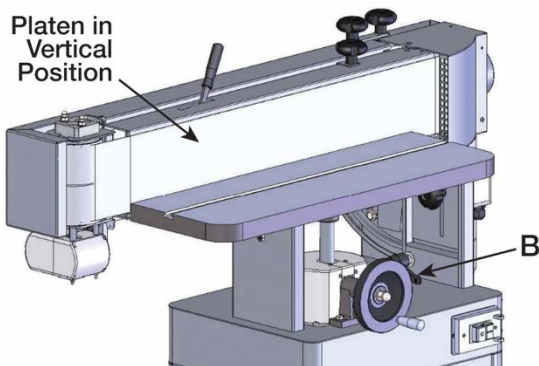

Figure 7-8

### 7.2.5 Adjusting Table Gap to Sanding Belt

Refer to Figure 7-9:

1. Loosen the four table mounting bolts (A) located under the table.
2. Shift the table position to provide a maximum gap of 1/16-inch between the table edge and sanding belt.
3. Tighten the four table mounting bolts to secure the table position.



Figure 7-9

### 7.2.6 Sanding Belt Installation

Refer to Figure 7-10:

1. From the rear of the sander, remove the belt guard (A) by unscrewing three lock knobs (B). Take out the sanding belt and removable fence from behind the belt guard.
2. Place the handle (C) on belt tensioning lever (D). Remove the tension from the mechanism by moving the tension arm handle (C) to the Loose position.
3. Place belt on both rollers so that the edge of the belt is even with the edge of the rollers.

**Note:** Make sure that direction arrow on belt matches the direction indicator on the top of the platen (E).

4. Tighten the sanding belt tension by moving the tension arm handle (C) to the "Tight" position. Rotate the belt by hand in the direction indicated by the arrow on top of the platen. If the belt tracking needs adjustment, see Section 9.3 *Belt Tracking Adjustment*.

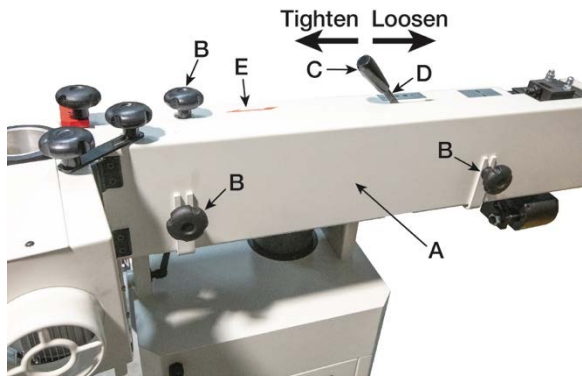

Figure 7-10

### 7.2.7 Extension Table

Refer to Figure 7-11:

1. Assemble the extension table (D) and extension table post (E) using the supplied M8x25 socket head cap screw.
2. Loosen the two lock knobs (A) that secure the dust port/drum guard (B).
3. Swing the dust port/drum guard back, exposing the drive drum (C).
4. Tighten the lock knobs (A).
5. Mount the extension table (D) to the sander by inserting the extension table post (E) into the bracket (F).
6. Set the table to the desired height, then secure into position by tightening the lock knob (G).

**Important:** The dust port/drum guard cannot be closed with the extension table in place. When not performing contour sanding, remove the extension table and store in the cabinet base. Close and lock the dust port/drum guard before sanding using the main table.

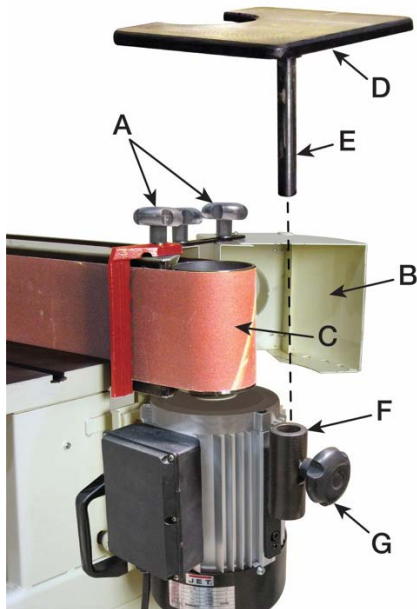

Figure 7-11

## 7.3 Dust Collection

Refer to Figures 7-12:

A sander produces a significant volume of wood dust. The use of a dust collection system is strongly recommended. It will help keep the shop clean, as well as reduce potential health hazards caused by inhalation of wood dust. We recommend your dust collector has a minimum rating of 400 CFM.

JET has a full line of dust collection systems available. See your dealer or visit our website at [www.jettools.com](http://www.jettools.com).

Connect the hose of your dust collection system to the 4-inch dust port on the sander (A). Secure hose tightly with a hose clamp.



Figure 7-12

## 8.0 Electrical Connections

**⚠WARNING** Electrical connections must be made by a qualified electrician in compliance with all relevant codes. This machine must be properly grounded to help prevent electrical shock and possible fatal injury.

Before connecting to power source, be sure OFF button is pressed.

It is recommended that the sander be connected to a dedicated 20-amp circuit with a 20-amp circuit breaker or time-delay fuse marked "D". **Local codes take precedence over recommendations.**

### 8.1 Grounding Instructions

This machine must be grounded. In the event of a malfunction or breakdown, grounding provides a path of least resistance for electric current to reduce the risk of electric shock. This tool is equipped with an electric cord having an equipment-grounding conductor and a grounding plug. The plug must be plugged into a matching outlet that is properly installed and grounded in accordance with all local codes and ordinances.

Do not modify the plug provided - if it will not fit the outlet, have the proper outlet installed by a qualified electrician.

Improper connection of the equipment-grounding conductor can result in a risk of electric shock. The conductor with insulation that is green, with or without yellow stripes, is the equipment-grounding conductor. If repair or replacement of the electric cord or plug is necessary, do not connect the equipment-grounding conductor to a live terminal.

**⚠WARNING** Check with a qualified electrician or service person if the grounding instructions are not completely understood, or if in doubt as to whether the machine is properly grounded. Failure to comply may cause serious or fatal injury.

### 8.2 115 Volt Operation

Referring to Figure 8-1:

This model is intended for use on a 115V circuit and has a grounded outlet that matches the machine's electrical cord plug, as shown in Figure 8-1.

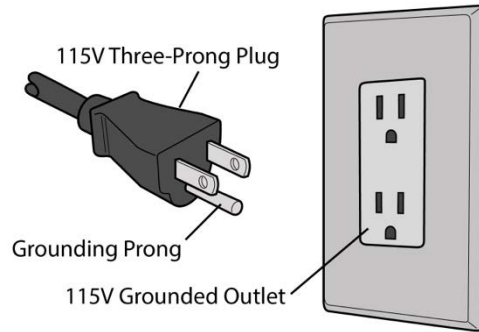

Figure 8-1: 115V Connection

If the outlet is not a properly grounded three-pole receptacle, do not use a temporary adaptor. Have a properly grounded three-pole receptacle installed by a qualified electrician.

### 8.3 230 Volt Operation

Referring to Figures 8-2 & 8-3:

If 230V, single-phase operation is desired, the machine must be rewired and a 230V plug and receptacle provided as shown in Figure 8-2. The following instructions must be followed:

Disconnect the machine from the power source.

1. The JET Oscillating Edge Sander motor has four numbered leads that are factory connected for 115V operation, as shown in (A). For 230V operation reconnect the leads as shown in (B).
2. The 115V attachment plug (C) supplied with the Oscillating Edge Sander must be replaced with a UL/CSA listed plug suitable for 230V operation (D). Contact your local Authorized JET Service Center or qualified electrician for proper procedures to install the plug. The Oscillating Edge Sander must comply with all local and national codes after the 230-volt plug is installed.
3. The Oscillating Edge Sander with a 230-volt plug should only be connected to an outlet having the same configuration as shown in (D). No adapter is available nor should be used with the 230-volt plug.

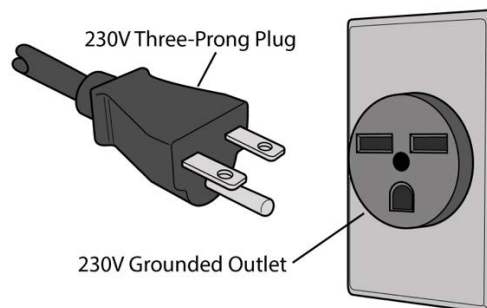

Figure 8-2

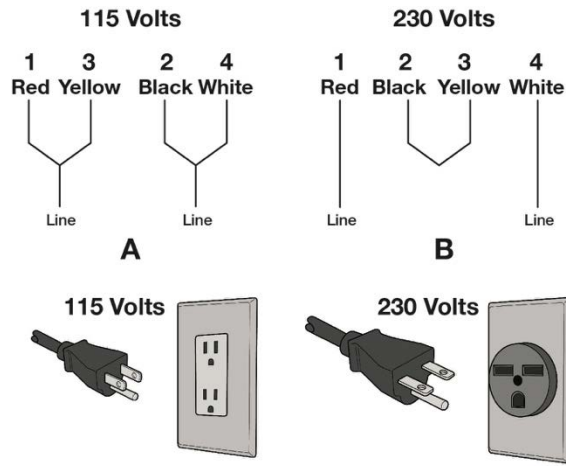

Figure 8-3

## 8.4 Extension Cords

The use of extension cords is discouraged. If possible, position your machine within reach of the power supply. If an extension cord becomes necessary, use only 3-wire extension cords that have 3-prong grounding plugs and 3-pole receptacles that accept the tool's plug. Make sure the cord rating is suitable for the amperage listed on the machine's motor plate. An undersized cord will cause a drop in line voltage resulting in loss of power and overheating.

Do not use a damaged or worn extension cord. Repair or replace before use.

Use Table 1 as a general guide in choosing the correct size cord. If in doubt, use the next heavier gauge. The smaller the gauge number, the heavier the cord.

### Recommended Gauges (AWG) of Extension Cords

| Amp Rating |               | Volts | Total length of cord in feet |     |                 |     |
|------------|---------------|-------|------------------------------|-----|-----------------|-----|
| More Than  | Not More Than |       | 25                           | 50  | 100             | 150 |
|            |               | 120   | 25                           | 50  | 100             | 150 |
|            |               | 240   | 50                           | 100 | 200             | 300 |
|            |               |       | AWG                          |     |                 |     |
| 0          | 6             |       | 18                           | 16  | 16              | 14  |
| 6          | 10            |       | 18                           | 16  | 14              | 12  |
| 10         | 12            |       | 16                           | 16  | 14              | 12  |
| 12         | 16            |       | 14                           | 12  | Not Recommended |     |

Table 1



## 9.0 Adjustments

**⚠WARNING** Before making adjustments, disconnect machine from the power source to guard against accidental startup.

**⚠CAUTION** This machine has an industrial-grade low-friction corrosion-resistant coating on the table and extension table. While the coating is durable, it can be damaged if metal or other hard and/or sharp objects strike, gouge, or scratch the surface. Significant damage to the coating may affect its performance. Use care when making adjustments to the machine.

### 9.1 Sanding Platen Angle and Table Adjustment

Refer to Figures 9-1 & 9-2:

1. Disconnect the machine from the power source.
2. Lower the table to the lowest position using the table adjustment handwheel (A, Figure 9-2). This will keep the sanding platen from contacting the table edge when the angle is adjusted.
3. Loosen locking handle (B, Figure 9-1).
4. Using the tilting handle (D, Figure 9-2), rotate sanding platen to the desired position. Use the angle readout gauge on underside of platen to set desired angle (C, Figure 9-1). For precise angles, use a combination square between the table and sanding belt.
5. Hold the platen in place and tighten the locking handle (B, Figure 9-1) to lock the platen assembly in place.
6. Raise the table to desired height. NOTE: The table horizontal position may need to be adjusted. See Section 7.2.5 Adjusting Table Gap to Sanding Belt. You may need to adjust both the table height and table horizontal position to provide the correct table-to-belt gap for the desired belt angle. Provide a maximum gap of 1/16-inch between the table edge and sanding belt.

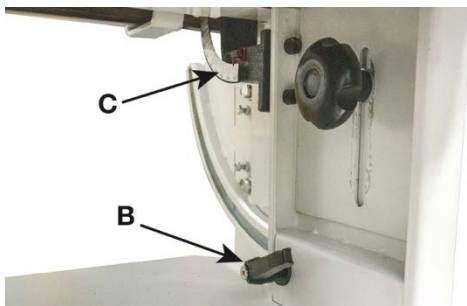

Figure 9-1



Figure 9-2

### 9.2 Changing the Sanding Belt

Refer to Figures 9-3 & 9-4:

1. Disconnect the machine from the power source.
2. Lock the sanding platen in the vertical position (see Section 9.1 Sanding Platen Angle Adjustment).
3. Remove the tension from the sanding belt by moving the tension handle (C) to the "Loose" position.
4. Loosen or remove the lock knobs (B) and remove the belt guard (A).
5. Remove the old belt and install the new belt matching the direction of the arrows on the belt with the arrow label on the top of the platen (E).
6. Line up edge of belt with edge of rollers.
7. Tighten the sanding belt tension by moving the tension arm handle (C) to the "Tight" position.
8. Reinstall the belt guard (A) and tighten the lock handles (B)

**Note:** Belts stretch with wear. When a belt is replaced, you may have to adjust tracking.

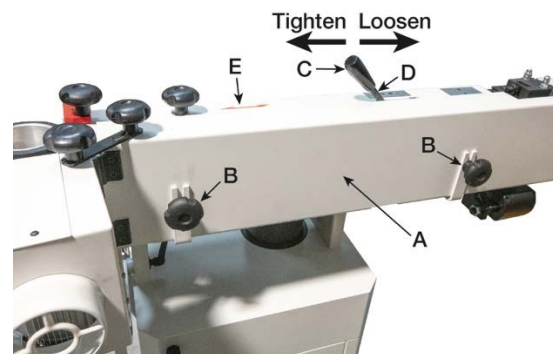

Figure 9-3

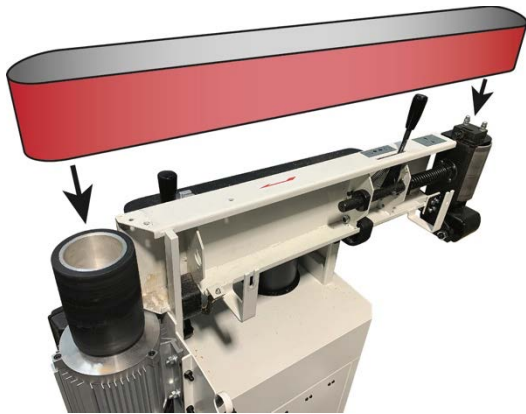

Figure 9-4

### 9.3 Belt Tracking Adjustment

Refer to Figure 9-5:

The Belt Tracking Adjustment is a fine adjustment procedure. The Motor Mount Tracking Adjustment (Section 9.4) is a coarse adjustment.

To adjust the belt tracking:

1. Disconnect the machine from the power source.
2. Push the belt by hand from left to right (the direction indicated top of the platen) and observe the belt's position on the rollers. The oscillating movement of the belt is by design. Observe the belt's range of movement from its highest to lowest position. The edges of the belt should not move above or below the edges of the rollers.

**If adjustment is still necessary:**

3. Insert the round shaft of the belt tracking adjustment tool (provided) into the micro adjust lock nut (A) and turn towards the back of the machine to loosen.
4. Turn the micro adjusting screw (B) in 1/4 turn increments until the belt tracks evenly on the rollers when rotated by hand.

Tip: Turning the micro adjusting screw (B) towards the back of the machine raises the belt on the drum. Turning it towards the front of the machine lowers the belt on the drum.

5. When adjustments are completed, tighten the micro adjusting lock nut (A) by turning it towards the front of the machine.

6. Connect the machine to power source and press the ON button to start sander. Observe the belt's up and down range of movement.

Adjustment is correct when the edges of the belt do not move above or below the edges of the rollers.

7. When adjustment is complete, make sure the micro adjust lock nut (A) is tightened.

If the tracking cannot be corrected, go to Section 9.4 *Motor Mount Tracking Adjustment*.

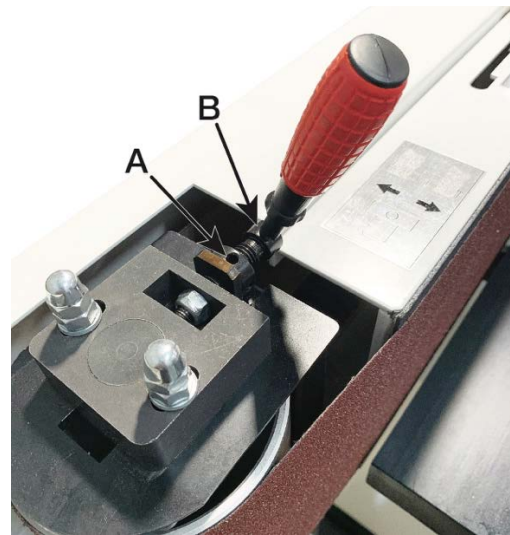

Figure 9-5

### 9.4 Motor Mount Tracking Adjustment

Refer to Figure 9-6:

The OES-689-BLK comes with tracking adjustment bolts (A) on the motor plate. These are set at the factory and should not require any further adjustment. If, however, you are not able to track the belt following the steps in Section 9.3 *Belt Tracking Adjustment*, the motor mount bolts will need to be adjusted.

**Note:** The Motor Mount Tracking Adjustment is a coarse adjustment. Use the Belt Tracking Adjustment (Section 9.3) first for fine adjustment. If it cannot be adjusted, then use the procedure described below.

To adjust:

1. Disconnect the machine from the power source.
2. Slightly loosen the four motor mount nuts (B) just enough so the tracking screws (A) can be turned to make an adjustment.
3. Loosen the two locking hex nuts (C) that secure the tracking screws (A).
4. Turn one screw (A) a 1/4 turn and rotate the sanding belt by hand to observe which direction the adjustment is causing the belt to move. If it is traveling in the direction needed to correctly track the belt go to step 6.
5. If the belt starts to travel in the wrong direction, back off a quarter turn and tighten the other screw a quarter turn. This should start the belt moving in the proper direction.
6. Tighten both locking nuts (C) and motor mount nuts (B). Return to Section 9.3 *Belt Tracking Adjustment* and fine tune the tracking.

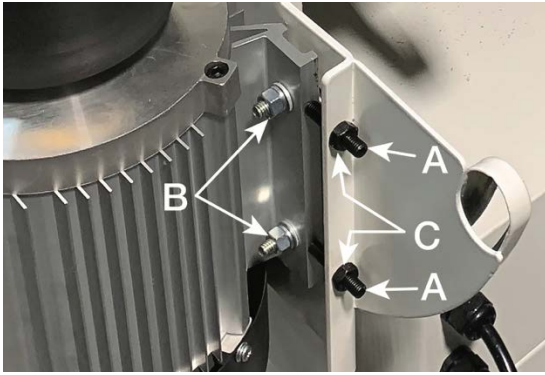

Figure 9-6

## 9.5 Table Adjustment

**⚠ WARNING** Do not position table below sanding belt! Keep an overlap of at least 1/16" between table and sanding belt to avoid material and/or fingers getting caught! Failure to comply may cause serious injury!

Refer to Figure 9-7:

1. Loosen two lock knobs (A).
2. Raise or lower work table to desired level by turning handwheel (B).
3. Tighten two lock knobs.



Figure 9-7

## 9.6 End Guard

Refer to Figure 9-8.

The end guard (C) on the right side of the machine can be swung out of the way for sanding long workpieces and for contour sanding using the extension table (see *Section 9.7 Extension Table*). NOTE: The miter gauge will need to be removed for sanding long workpieces.

1. Loosen the two lock knobs (A & B) that secure the dust port/drum guard (C).
2. Swing the dust port/drum guard back, exposing the drive drum (D).
3. If sanding long work pieces, remove lock knob A and remove the backstop (E).

4. Tighten lock knob B to lock dust port/drum guard in the open position.
5. If performing contour sanding, see *Section 7.2.6 Extension Table*, to install the extension table.

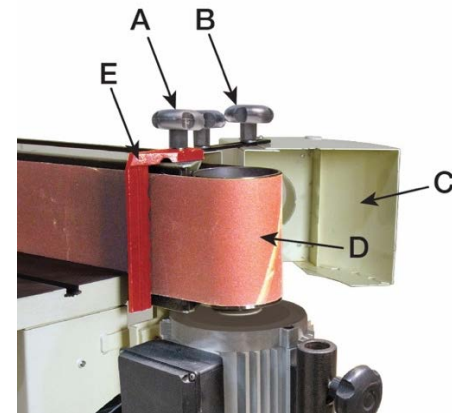

Figure 9-8

## 9.7 Extension Table

Refer to Figure 9-9.

The extension table allows contour sanding. The extension table can be raised and lowered. To attach and use the extension table, see *Section 7.2.6 Extension Table*.



Figure 9-9



## 10.0 Operation

**⚠WARNING** Read and understand all safety information in Section 3.0 *Safety Warnings* before operating this machine.

**⚠CAUTION** This machine has an industrial-grade low-friction corrosion-resistant coating on the table and extension table. While the coating is durable, it can be damaged if metal or other hard and/or sharp objects strike, gouge, or scratch the surface. Significant damage to the coating may affect its performance. Use care when operating the machine.

Your oscillating belt edge sander is designed and manufactured for long-term operation creating superior sanded surfaces for wood products. The oscillation of the belt helps prevent sanding marks in the workpiece and allows longer belt wear.

Always use the miter gauge, when possible, to support your workpiece.

**⚠CAUTION** This machine is suited for sanding wood products only. Do not use this machine for sanding metal products.

### 10.1 Horizontal Sanding

Refer to Figures 10-1 & 10-2:

For horizontal sanding, the platen is locked in the horizontal position as shown in Figure 10-2 and the removable fence (D, Figure 10-2) is secured to the table as follows.

1. Place platen in the horizontal position (see Section 9.1 *Sanding Platen Angle Adjustment*).
2. Place 5/16 flat washers (not shown) and guide blocks (B) on two 12mm lock knobs (A) – Note: the 12mm refers to the threaded shaft length.
3. Insert both guide blocks/lock knobs into the miter slot (C).
4. Place the removable fence (D, Figure 10-2) on the table and secure by tightening the lock knobs (A, Figure 10-2).

The backstop (E, Figure 10-2) can also be used by swiveling the dust port/drum guard (F, Figure 10-2) out of the way and placing the backstop in position and securing in place with the lock knob (G, Figure 10-2) and 5/16" flat washer.

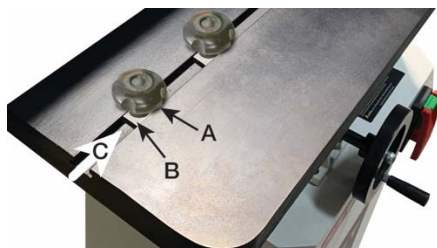

Figure 10-1



Figure 10-2

### 10.2 Vertical Sanding

Refer to Figure 10-3:

For vertical sanding, the platen (A) is locked in the vertical position as shown in Figure 10-3. The backstop (B) and/or the miter gauge (C) may be used.

#### Miter Gauge

1. Slide the guide bar (D) of the miter gauge (C) into the miter slot (E) on the table.
2. Set the miter angle; then secure the miter by tightening the lock handle (F).

#### Backstop

Place the backstop (B) in position and secure in place with the lock knob (G) and 5/16" flat washer.

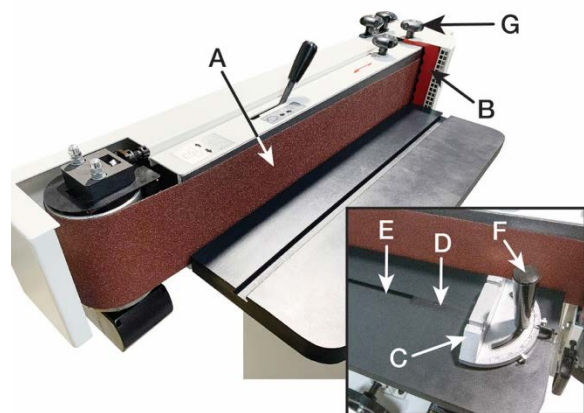

Figure 10-3

### 10.3 Contour Sanding

Refer to Figure 10-4.

Contour sanding is done from the extension table (D) mounted on the motor where the sanding belt wraps around the drive drum (C). To set up the sander for contour sanding:

1. Loosen the two lock knobs (A) that secure the dust port/drum guard (B).
2. Swing the dust port/drum guard back, exposing the drive drum (C).
3. Tighten the lock knobs (A).
4. Mount the extension table (D) to the sander by inserting the post (E) into the bracket (F).
5. Set the table to the desired height, then secure into position by tightening the lock knob (G).

**Important:** When the extension table is not in use, the dust port/drum guard should always be in the closed and locked position so the drive drum is not in exposed.

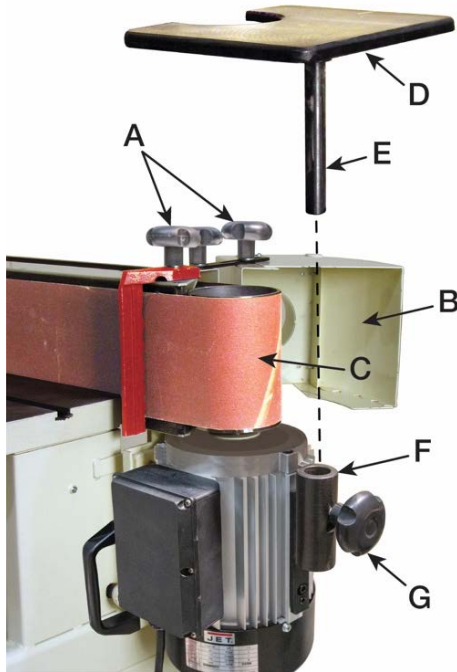

Figure 10-4:

## 11.0 Maintenance

**⚠WARNING** Always disconnect power to the machine and remove the safety key before performing maintenance. Failure to do this may result in serious personal injury.

**⚠CAUTION** This machine has an industrial-grade low-friction corrosion-resistant coating on the table and extension table. While the coating is durable, it can be damaged if metal or other hard and/or sharp objects strike, gouge, or scratch the surface. Significant damage to the coating may affect its performance. Use care when performing maintenance on this machine.

Periodically check both drums. The drums are made of rubber material and may experience wear after a long period of use, at which time they should be replaced.

The sander should be cleaned frequently.

Check all screws, hex nuts, and other fasteners to make sure they are tight.

Check condition of sanding belt. If belt is worn, replace it.

If the power cord is worn, cut, or damaged in any way, have it replaced immediately.

### 11.1 Lubrication

All ball bearings are sealed for life and do not require further lubrication.

Periodically apply grease to the table lift worm gear for smooth operation.

## 12.0 Troubleshooting

| Trouble   | Probable Cause                          | Remedy   |
|---|---|--|
| Machine will not start/restart or repeatedly trips circuit breakers or blows fuses. | Machine not connected to power source.  | Verify machine is connected to power.  |
|   | Fuse blown, or circuit breaker tripped. | Replace fuse or reset circuit breaker.   |
|   | Cord damaged.                           | Replace cord.  |
|   | Extension cord too light or too long.   | Use adequate size extension cord.  |
|   | Power line overload.                    | Press red STOP button. Correct overload condition. Use dedicated circuit for sander. |

| <b>Trouble</b>                                   | <b>Probable Cause</b>                         | <b>Remedy</b>   |
|--|---|---|
|  | Edge Sander frequently trips.                 | Match the full load amps on the motor as noted on the motor plate. If amp setting is correct, there is probably a loose electrical lead or a failed component. See below.   |
|  | Building circuit breaker trips or fuse blows. | Verify that edge sander is on a circuit of correct size. If circuit size is correct, there is probably a loose electrical lead.   |
|  | Loose electrical connections.                 | Go through all the electrical connections on the edge sander including motor connections, verifying the tightness of each. Look for any signs of electrical arcing which is a sure indicator of loose connection or circuit overload.   |
|  | Motor starter failure.                        | If you have access to a voltmeter, you can separate a starter failure from a motor failure by first, verifying incoming voltage is correct and second, checking for correct voltage between starter and motor. If incoming voltage is incorrect, you have a power supply problem. If voltage between starter and motor is incorrect, you have a starter problem. If voltage between starter and motor is correct, you have a motor problem. |
|  | Motor failure.                                | If electric motor is suspect, you have two options: Have a qualified electrician test the motor for function or remove the motor and take it to a qualified electric motor repair shop and have it tested.  |
|  | Miswiring of the unit.                        | Check to make certain all electrical connections are correct and properly tight. The electrical connections other than the motor are preassembled and tested at the factory. Therefore, the motor connections should be checked as the highest probability for error. If problems persist, double check the factory wiring.   |
|  | On/off switch failure.                        | If the on/off switch is suspect, you have two options: Have a qualified electrician test the switch for function or purchase a new on/off switch and establish if that was the problem on changeout.  |
| Sanding belt won't come up to speed.             | Extension cord too light or too long.         | Use adequate size extension cord.   |
| Sanding belt won't come up to speed.             | Low (incoming) voltage.                       | Contact qualified electrician.  |
|  | Excessive bite, or feed pressure too great.   | Allow sanding belt to cut freely, do not force.   |
| Belt won't track.                                | Drum is worn.                                 | Replace drum.   |
|  | Belt is stretched unevenly.                   | Replace belt.   |
| Belt slips or stalls on application of pressure. | Sanding belt tension not adequate.            | Make sure lever is down all the way.  |
| Excessive sanding belt replacement.              | Too much pressure being used during cuts.     | Reduce pressure.  |
|  | Not using full width of belt.                 | Stroke across the belt using full width.  |

| <b>Trouble</b>   | <b>Probable Cause</b>                              | <b>Remedy</b>  |
|--|--|--|
| Machine vibrates excessively.                              | Improper motor mounting.                           | Check and adjust mounting.   |
|  | Spring on tension mechanism is fatigued or broken. | Replace with new spring.   |
|  | Drum is loose.                                     | Tighten cap screw in motor.  |
|  | Bad or broken sanding belt.                        | Replace sanding belt.  |
| Sanding marks on workpiece.                                | Sanding belt too coarse for required finish.       | Use proper grit. Coarser grits for stock removal, and finer grits for finish work.   |
|  | Workpiece sanded across grain.                     | When surface sanding, use very fine sanding belt then finish by hand, working in direction of grain.   |
| Sanding grains quickly rub off belt.                       | Sanding belt has lost its original properties.     | Do not store sanding belts in extremely dry or high-temperature areas. Do not fold sanding belts.  |
| Sanding belt becomes glazed.                               | Sanding painted surface.                           | Use open-end grain/flint belt.   |
|  | Wood is wet or gummy.                              | No cure. Use different stock.  |
| Work burns.  | Wrong sanding belt surface.                        | Use coarser grit for stock removal.  |
|  | Feed pressure too great.                           | Never force workpiece into steel platen. Use just enough pressure and let the sanding belt do the work.  |
| Sanding belt burns, or clogs quickly on thickness sanding. | Biting too deep.                                   | Adjust for slight sanding action and make repeated passes.   |
| Workpiece pulled from hand.                                | No support for workpiece.                          | Use miter gauge on table.  |
| Sanding belt has broken at the joint.                      | Belt running in wrong direction.                   | Orient direction of arrows printed on sanding belt to match rotation of drums. Sanding belt should move left to right as viewed from front of machine. |
| Sanded edge is not square.                                 | Result of freehand sanding.                        | Keep workpiece flat on table at all times when a square edge is desired. Use miter gauge.  |
|  | Sanding belt angle misaligned.                     | Check belt angle alignment to table with a square or machinist's protractor. It should be 90 degrees. Adjust belt angle if necessary.                  |

## 13.0 Replacement Parts

Replacement parts are listed on the following pages. To order parts or reach our service department, call 1-800-274-6848 Monday through Friday, 8:00 a.m. to 5:00 p.m. CST. Having the Model Number and Serial Number of your machine available when you call will allow us to serve you quickly and accurately.

Non-proprietary parts, such as fasteners, can be found at local hardware stores, or may be ordered from JET.

Some parts are shown for reference only and may not be available individually.

13.1.1 OES-689-BLK Cabinet Assembly – Exploded View

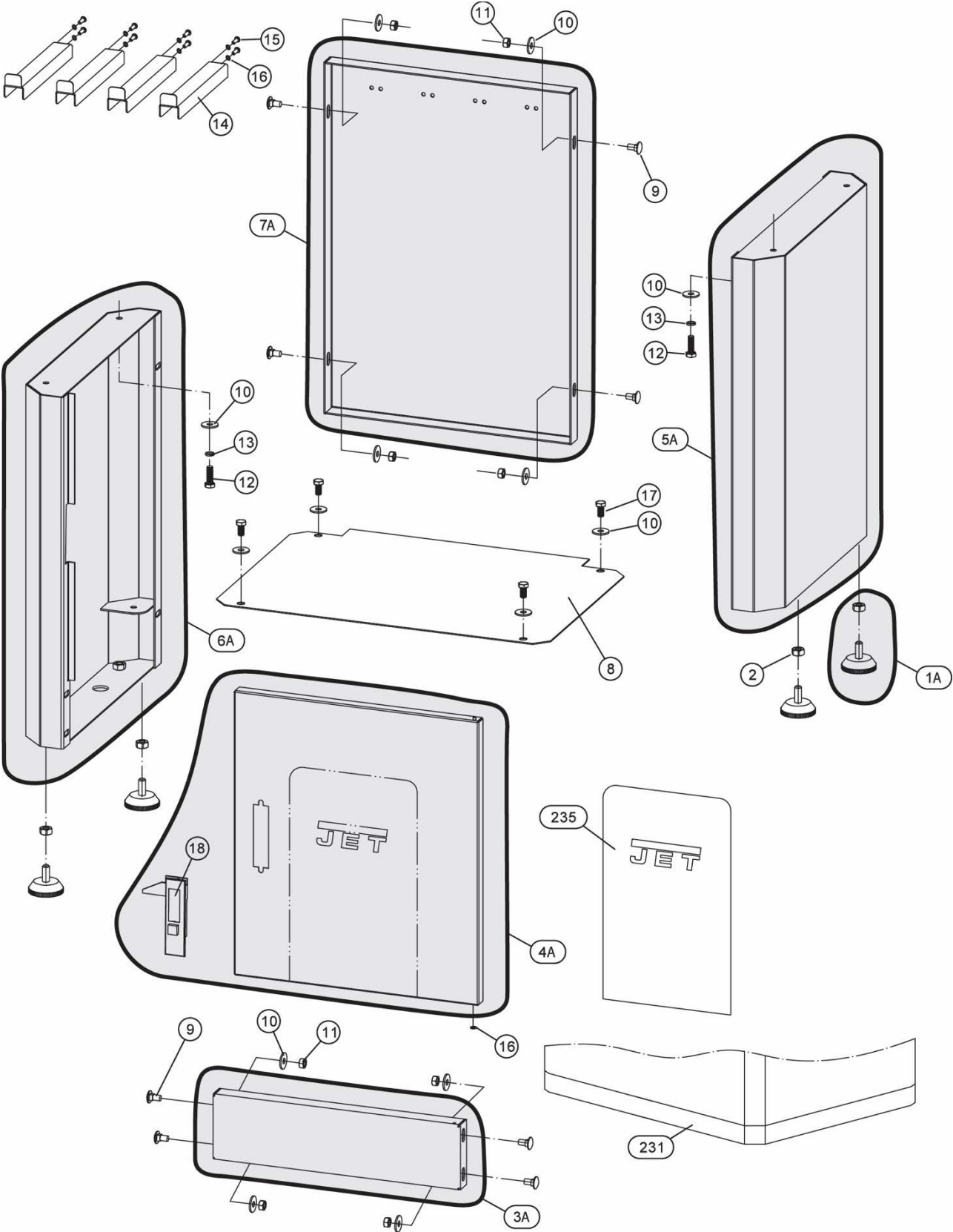





13.1.3 OES-689-BLK Table Asseby – Exploded View

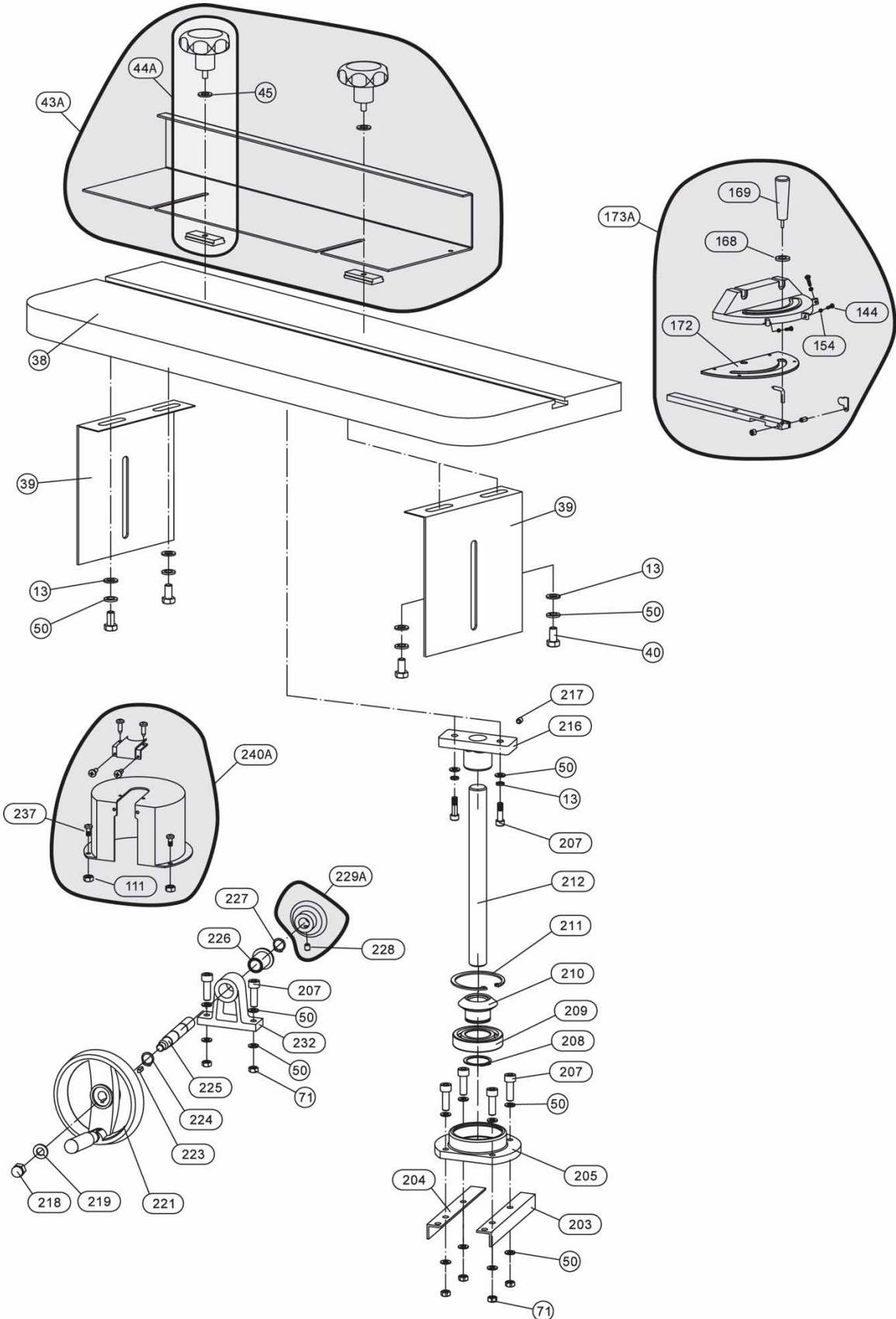

## 13.2 OES-689-BLK Oscillating Edge Sander – Parts List

| Index No. | Part No.       | Description                    | Size      | Qty |
|-----------|----------------|--------------------------------|-----------|-----|
| 1A        | OES689BLK-001A | Foot Assembly                  |           | 4   |
| 2         | **             | Hex Nut                        | M10       | 4   |
| 3A        | OES689BLK-003A | Front Panel Assembly           |           | 1   |
| 4A        | OES689BLK-004A | Door for Stand Assembly        |           | 1   |
| 5A        | OES689BLK-005A | Side Panel Right Assembly      |           | 1   |
| 6A        | OES689BLK-006A | Side Panel Left Assembly       |           | 1   |
| 7A        | OES689BLK-007A | Rear Panel Assembly            |           | 1   |
| 8         | OES689BLK-008  | Bottom Panel                   |           | 1   |
| 9         | OES689BLK-009  | Carriage Bolt                  | M8x16     | 8   |
| 10        | OES689BLK-010  | Large Flat Washer              | M8        | 24  |
| 11        | **             | Hex Nut                        | M8        | 20  |
| 12        | **             | Hex Cap Screw                  | M8x25     | 4   |
| 13        | **             | Lock Washer                    | 8mm       | 13  |
| 14        | OES689BLK-014  | Trestle                        |           | 4   |
| 15        | **             | Socket Head Button Screw       | M5x10     | 8   |
| 16        | **             | Flat Washer                    | 5mm       | 9   |
| 17        | **             | Hex Cap Screw                  | M8x16     | 4   |
| 18        | OES689BLK-018  | Latch Assembly                 |           | 1   |
| 19        | OES689BLK-019  | Locking slider                 |           | 1   |
| 20        | OES689BLK-020  | Knob                           |           | 2   |
| 21        | OES689BLK-021  | Large Washer 8                 | 8mm       | 2   |
| 22A       | OES689BLK-022A | Angle Plate Assembly           |           | 2   |
| 23        | **             | Hex Socket Head Screw          | M8x25     | 4   |
| 24        | OES689BLK-024  | Base                           |           | 1   |
| 25        | OES689BLK-025  | Lock Handle                    |           | 1   |
| 26        | OES689BLK-026  | Flat Washer                    | 10mm      | 1   |
| 27        | OES689BLK-027  | Screw                          | M10       | 2   |
| 28        | **             | Flat Washer                    | 10mm      | 2   |
| 29        | OES689BLK-029  | Butterfly Washer               | 10mm      | 1   |
| 30        | **             | Nylon Lock Hex Nut             | M10       | 2   |
| 31        | OES689BLK-031  | Nylon Washer                   |           | 1   |
| 32        | OES689BLK-032  | Lock Nut                       |           | 1   |
| 33        | JDP17-100      | Switch                         |           | 1   |
| 34        | **             | Pan Head Machine Screw         | M4x12     | 2   |
| 35        | **             | Pan Head Machine Screw         | M5x10     | 1   |
| 37A       | OES689BLK-037A | Pointer Assembly               |           | 1   |
| 38        | OES689BLK-038  | Table (PTFE)                   |           | 1   |
| 39        | OES689BLK-039  | Work Table Mounting Plate      |           | 1   |
| 40        | **             | Hex Cap Screw                  | M8x16     | 4   |
| 43A       | OES689BLK-043A | Fence Assembly (with PC Label) |           | 2   |
| 44A       | OES689BLK-044A | Guide Block Assembly           | 6 mm      | 2   |
| 45        | **             | Flat Washer                    |           | 2   |
| 47        | OES689BLK-047  | Sanding Platen                 |           | 1   |
| 48        | OES689BLK-048  | Graphite Pad                   |           | 1   |
| 49        | **             | Hex Cap Screw                  | M8x20     | 1   |
| 50        | **             | Flat Washer                    | 8mm       | 15  |
| 51        | OES689BLK-051  | Ring                           |           | 2   |
| 52        | **             | Nylon Lock Hex Nut             | M6        | 4   |
| 53        | **             | Hex Socket Head Screw          | M6x20     | 4   |
| 54        | **             | Hex Cap Screw                  | M8x45     | 1   |
| 55A       | OES689BLK-055A | Belt Tension Arm Assembly      |           | 1   |
| 56        | OES689BLK-056  | Tension Arm Handle             |           | 1   |
| 57        | **             | Nylon Lock Hex Nut             | M8        | 1   |
| 58        | OES689BLK-058  | Tension Bar                    |           | 1   |
| 59        | OES689BLK-059  | Spring                         |           | 1   |
| 60        | **             | Hex Socket Head Screw          | M5x12     | 4   |
| 61        | **             | Lock Washer                    | 5 mm      | 4   |
| 62        | **             | Flat Washer                    | 5 mm      | 4   |
| 63        | OES689BLK-063  | Bearing Housing                |           | 1   |
| 64        | OES689BLK-064  | Ball Bearing                   | 16003/2RZ | 2   |
| 67        | **             | Hex Cap Screw                  | M8x20     | 1   |
| 68        | OES689BLK-068  | Idle Drum Bracket              |           | 1   |
| 71        | **             | Nylon Lock Hex Nut             | M8        | 9   |
| 72        | **             | Cap Nut                        | M8        | 2   |



| Index No. | Part No.       | Description                    | Size              | Qty |
|-----------|----------------|--------------------------------|-------------------|-----|
| 75        | OES689BLK-075  | Double-Screw Bolt              |                   | 2   |
| 77A       | OES689BLK-077A | Track Adjusting Block Assembly |                   | 1   |
| 78        | OES689BLK-078  | Ball Bearing                   |                   | 1   |
| 79        | OES689BLK-079  | Guard                          |                   | 1   |
| 80        | OES689BLK-080  | Idle Drum                      |                   | 1   |
| 80A       | OES689BLK-080A | Idle Drum Assembly             |                   | 1   |
| 81        | OES689BLK-081  | Idle Drum Shaft                |                   | 1   |
| 84        | OES689BLK-084  | Retaining C-Ring               | 22mm              | 1   |
| 85        | OES689BLK-085  | Down Bearing Housing           |                   | 1   |
| 86        | **             | Flat Head Machine Screw        | M4x12             | 3   |
| 87        | OES689BLK-087  | Ball Bearing                   |                   | 1   |
| 88        | OES689BLK-088  | Worm                           |                   | 1   |
| 93A       | OES689BLK-093A | Dust Hood Box Assembly         |                   | 1   |
| 96        | **             | Nylon Lock Hex Nut             | M5                | 2   |
| 99        | OES689BLK-099  | Ball Bearing                   | 619/8 2RZ         | 2   |
| 101       | OES689BLK-101  | Gear Housing                   |                   | 1   |
| 102       | OES689BLK-102  | Cam                            |                   | 1   |
| 103       | OES689BLK-103  | Worm Gear                      |                   | 1   |
| 105       | OES689BLK-105  | Worm Gear Shaft                |                   | 1   |
| 107       | **             | Flat Washer                    | 5 mm              | 4   |
| 108       | **             | Lock Washer                    | 5 mm              | 4   |
| 109       | **             | Socket Head Cap Screw          | M5x10             | 4   |
| 111       | **             | Hex Nut                        | M6                | 29  |
| 112A      | OES689BLK-112A | Spring Assembly                |                   | 1   |
| 113       | OES689BLK-113  | Sanding Belt                   |                   | 1   |
| 114       | **             | Hex Nut                        | M16               | 1   |
| 115       | OES689BLK-115  | Bracket                        |                   | 1   |
| 116       | **             | Flat Washer                    | 6 mm              | 4   |
| 117       | **             | Lock Washer                    | 6 mm              | 1   |
| 118       | **             | Socket Head Cap Screw          | M6x16             | 8   |
| 119A      | OES689BLK-119A | Spring Assembly                |                   | 1   |
| 125       | **             | Pan Head Machine Screw         | M5x16             | 1   |
| 126       | **             | Flat Washer                    | 5 mm              | 2   |
| 127       | **             | Flat Washer                    | 5 mm              | 2   |
| 128       | **             | Hex Nut                        | M5                | 1   |
| 129A      | OES689BLK-129A | Bracket Assembly               |                   | 1   |
| 132       | OES689BLK-132  | Knob                           |                   | 1   |
| 134       | OES689BLK-134  | Socket Set Screw               | M8x40             | 3   |
| 135A      | OES689BLK-135A | Handle Assembly                |                   | 1   |
| 136       | **             | Socket Head Cap Screw          | M8x16             | 2   |
| 137       | **             | Hex Cap Screw                  | M8x30             | 4   |
| 141       | OES689BLK-141  | Motor Assembly                 | 1-3/4HP/115V/230V | 1   |
|           | OES689BLK-141W | Wiring Diagram (Not Shown)     |                   | 1   |
|           | OES689BLK-141L | Motor Label (not shown)        |                   | 1   |
|           | OES689BLK-141F | Motor Fan (not shown)          |                   | 1   |
|           | OES689BLK-141C | Motor Fan Cover (not shown)    |                   | 1   |
|           | OES689BLK-141R | Running Capacitor (not shown)  | 120µF, 250V AC    | 1   |
|           | OES689BLK-141J | Junction Box (not shown)       |                   | 1   |
|           | OES689BLK-141B | Junction Box Cover (not shown) |                   | 1   |
|           | OES689BLK-141K | Key (Not Shown)                |                   | 1   |
| 142       | OES689BLK-142  | Drive Drum                     |                   | 1   |
| 143       | OES689BLK-143  | Special Washer                 |                   | 1   |
| 144       | **             | Pan Head Machine Screw         | M4x16             | 1   |
| 145       | **             | Hex Cap Screw                  | M8x25             | 4   |
| 146       | **             | Socket Head Cap Screw          | M6x12             | 2   |
| 147       | OES689BLK-147  | Supporting Seat                |                   | 1   |
| 148       | OES689BLK-148  | Knob                           |                   | 1   |
| 149       | OES689BLK-149  | Supporting Rod                 |                   | 1   |
| 150       | **             | Socket Head Cap Screw          | M8x25             | 1   |
| 151       | OES689BLK-151  | Extension Table (PTFE)         |                   | 1   |
| 152       | **             | Pan Head Machine Screw         | M4x12             | 3   |
| 154       | **             | Hex Nut                        | M4                | 3   |
| 155A      | OES689BLK-155A | Dust Port Assembly             |                   | 1   |
| 157       | **             | Flat Head Machine Screw        | M6x20             | 8   |
| 158       | OES689BLK-158  | Hinge                          |                   | 1   |
| 159       | OES689BLK-159  | Connection Plate               |                   | 1   |

| Index No. | Part No.       | Description  | Size          | Qty |
|-----------|----------------|--|---------------|-----|
| 160       | OES689BLK-160  | Large Flat Washer  | 8mm           | 5   |
| 161       | OES689BLK-161  | Knob   |               | 3   |
| 162       | OES689BLK-162  | Sanding Belt Cover   |               | 1   |
| 163       | OES689BLK-163  | Knob   |               | 2   |
| 164       | OES689BLK-164  | Miter Gauge Body   |               | 1   |
| 165       | OES689BLK-165  | Guide Bar  |               | 1   |
| 166       | **             | Socket Set Screw   | M6x6          | 1   |
| 167       | OES689BLK-167  | Pointer  |               | 1   |
| 168       | **             | Large Flat Washer  | 6 mm          | 1   |
| 169       | OES689BLK-169  | Knob   |               | 1   |
| 170       | OES689BLK-170  | Pin  |               | 1   |
| 171       | OES689BLK-171  | Stopper  |               | 1   |
| 172       | OES689BLK-172  | Pom Pad  |               | 1   |
| 173A      | OES689BLK-173  | Miter Gauge Assembly   |               | 1   |
| 174       | OES689BLK-174  | Adjusting Wrench   |               | 1   |
| 175       | OES689BLK-175  | Strain Relief  |               | 2   |
| 176       | OES689BLK-176  | Power Cord 14AWGx3C, 5-15P/115V  | Prewired 115V | 1   |
| 177       | **             | Socket Set Screw   | M8x12         | 1   |
| 178       | **             | Flat Washer  | 6 mm          | 4   |
| 179       | **             | Lock Washer  | 6 mm          | 4   |
| 203       | OES689BLK-203  | Left Angle Iron  |               | 1   |
| 204       | OES689BLK-204  | Right Angle Iron   |               | 1   |
| 205       | OES689BLK-205  | Bearing Housing  |               | 1   |
| 207       | **             | Socket Head Cap Screw  | M8x30         | 8   |
| 208       | OES689BLK-208  | C-Ring   | 40mm          | 1   |
| 209       | BB-6208ZZ      | Ball Bearing   | 6208/2RZ      | 1   |
| 210       | OES689BLK-210  | Bevel Gera   |               | 1   |
| 211       | OES689BLK-211  | C-Ring   | 80mm          | 1   |
| 212       | OES689BLK-212  | Shaft  |               | 1   |
| 216       | OES689BLK-216  | Lifting Seat   |               | 1   |
| 217       | **             | Socket Set Screw   | M8x10         | 1   |
| 218       | **             | Hex Nut  | M12           | 1   |
| 219       | **             | Flat Washer  | 12mm          | 1   |
| 221       | OES689BLK-221  | Handwheel  |               | 1   |
| 223       | OES689BLK-223  | Key  | A5x16         | 1   |
| 224       | OES689BLK-224  | C- Ring  | 18 mm         | 1   |
| 225       | OES689BLK-225  | Shaft  |               | 1   |
| 226       | OES689BLK-226  | Shaft Bush   |               | 1   |
| 227       | OES689BLK-227  | C- Ring  | 18 mm         | 1   |
| 228       | **             | Socket Set Screw   | M8x10         | 1   |
| 229A      | OES689BLK-229A | Bevel Gear Assembly  |               | 1   |
| 231       | OES689BLK-231  | Black Sticker for Stand  |               | 1   |
| 232       | OES689BLK-232  | Shaft Bracket  |               | 1   |
| 233       | OES689BLK-233  | Warning Label, OES-689-BLK   |               | 1   |
| 234       | OES689BLK-234  | OES689 Model Logo with Adhesive  |               | 1   |
| 235       | OES689BLK-235  | JET Logo with Adhesive   | 8x15T         | 1   |
| 236       | OES689BLK-236  | Protection Guard   |               | 1   |
| 237       | **             | Pan Head Machine Screw   | M6x16         | 3   |
| 238       | OES689BLK-238  | Self Tapping Screws  | ST4x10        | 4   |
| 239       | OES689BLK-239  | Small Cover  |               | 1   |
| 240A      | OES689BLK-240  | Protection Guard Assembly  |               | 1   |
| WS        | OES689BLK-WS   | Hex Wrench Set   |               | 1   |
| BHK       | OES689BLK-BHK  | Base Hardware Pack (includes quantity needed for cabinet assembly for items #1, 2, 9, 10, 11, 12, 13, 15, 16, 17, 148) |               | 1   |

\*\* Some parts are shown for reference only and may not be available for order individually. Non-proprietary parts, such as fasteners, can usually be found at local hardware stores.

# 14.0 Electrical Connections

## 14.1 Electrical Connections for 1.75HP, 1PH, 115V

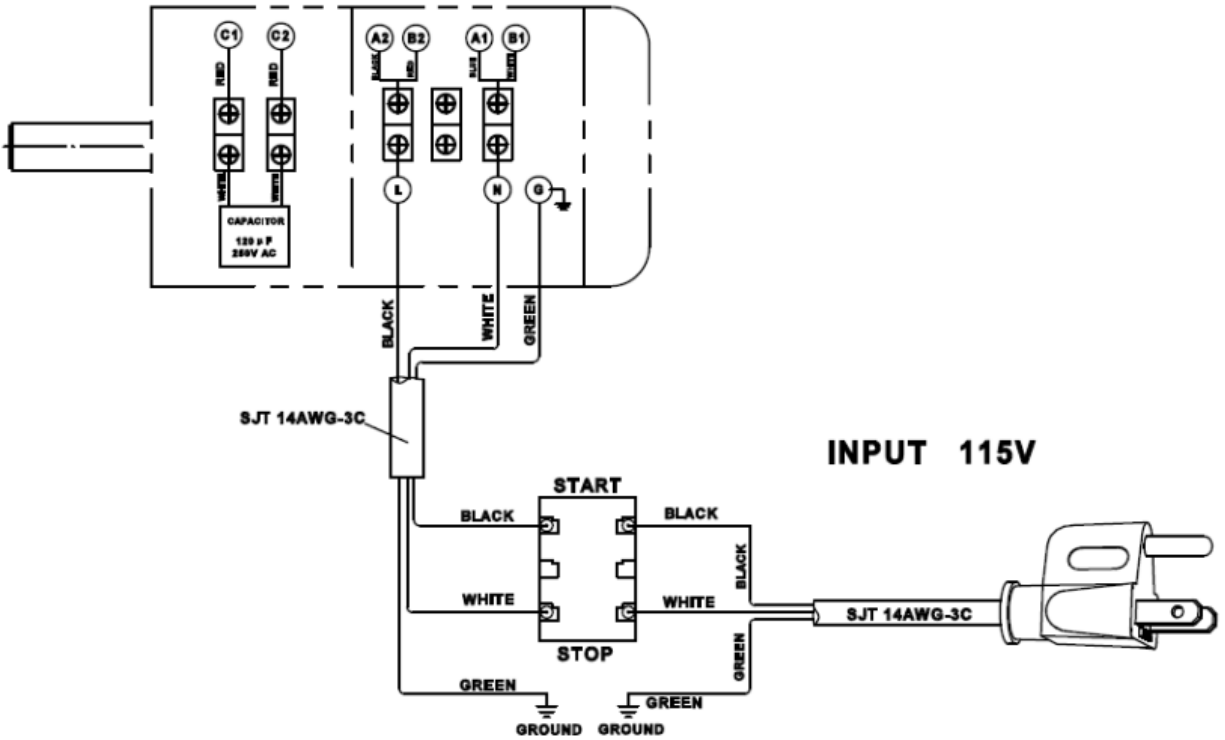

## 14.2 Electrical Connections for 1.75HP, 1PH, 230V

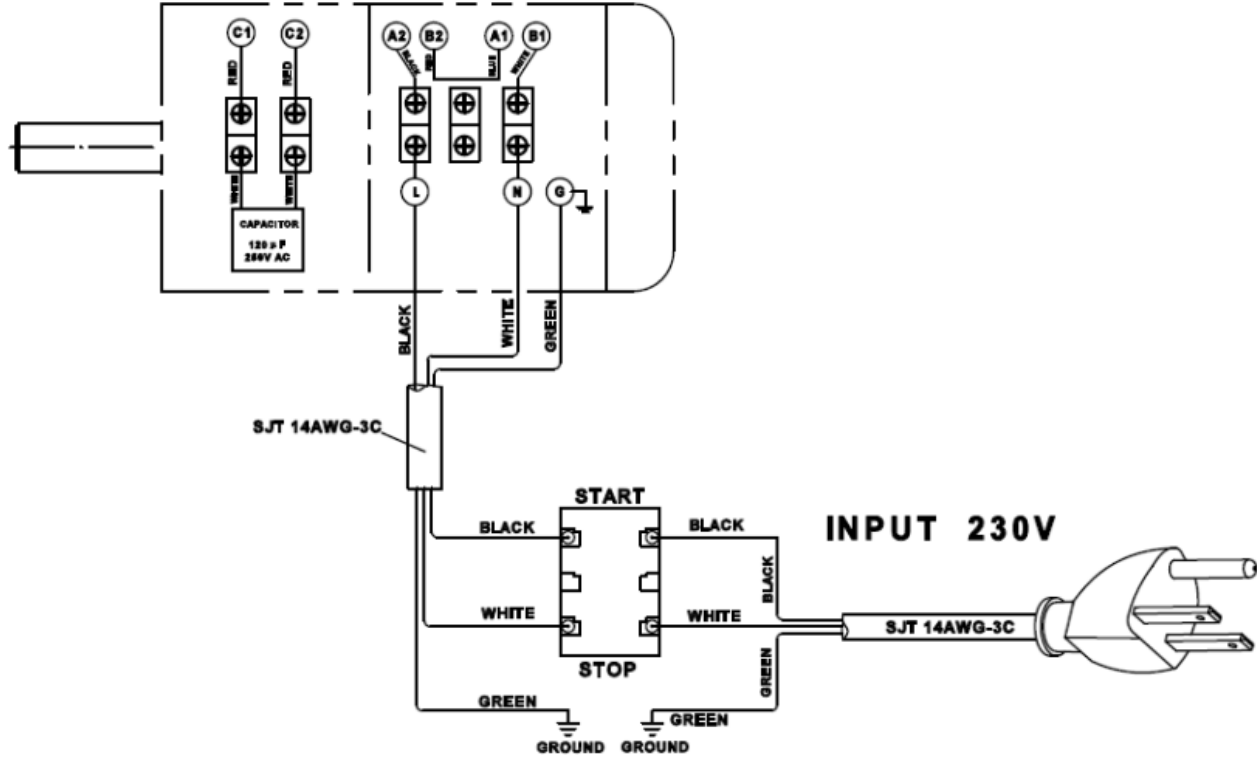



427 New Sanford Road  
LaVergne, Tennessee 37086  
Phone: 800-274-6848  
[www.jettools.com](http://www.jettools.com)