

MINI BEAM STAKE & SHIELD



DESCRIPTION

The Mini Beam is the perfect lamp to bring light to hard-to-reach places, whether under water, in a water feature, under stairs, stone walls, stone lanterns, or any small space. This directional product solves the issue of fitting a fixture and a lamp into a small area. Enhanced ESD (Electro-Static Discharge) protection (IEC-61000-4-2). We recommend using LightingShrink connections for Mini Beams. Dimmable with Brilliance Dimmer and most magnetic transformers. Now packaged and pre-assembled with the Stake & Shield accessory. If your application calls for it, shape or bend the stake to optimize the light's aim.

MINI BEAM

| | |
|-----------------|---|
| Use | Fully Submersible in Water Features or Heavy Irrigation Areas Small Spaces that Need Directional Light |
| Finish | Brass |
| Includes | 12 ft Lead |
| Integrated Lamp | Mini Beam - 1.5W, 36°, CRI 80, IP68, 8-15VAC, 2.50VA, 3 year warranty, 30,000 hours Amber MINI-BEAM-AMBER-90 |

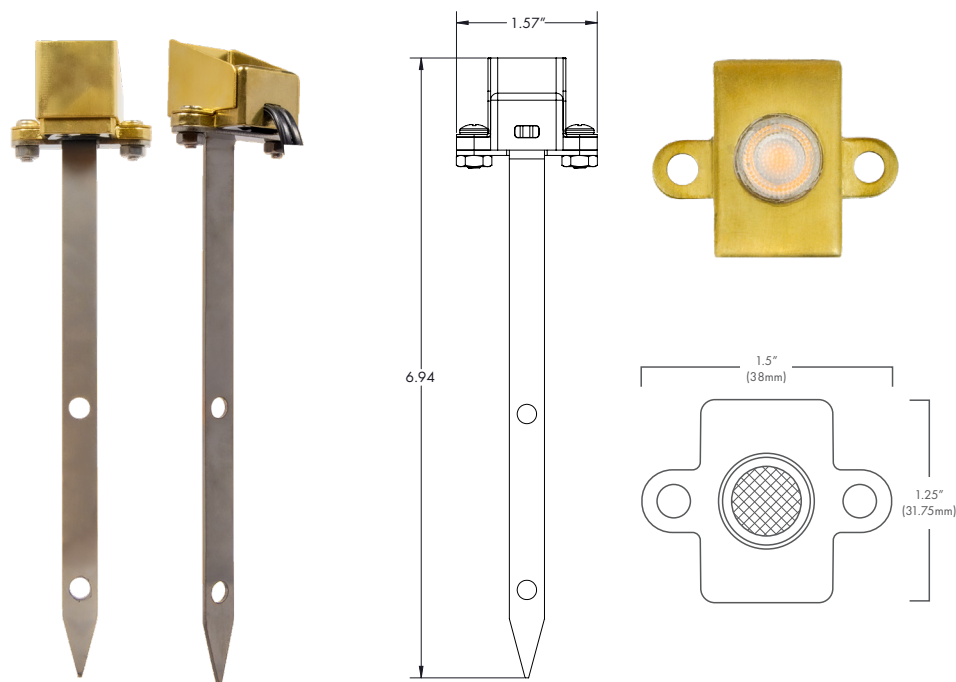

*Note: Corrosive chemicals in the water of ponds and fountains as well as natural hard water and salt water could affect the appearance of the coating, but will not impact functionality of the product. For this reason, Brilliance LED makes no warranty or guarantee for change in appearance when this product is used in water, as it is designed to be used. (NOT for use in swimming pools, spas, or any contained water basin in contact with people per NEC Article 682.)

UNDER REVIEW FOR WILDLIFE LIGHTING CERTIFICATION PROGRAM

The Wildlife Lighting Certification Program has been suspended since 2020 due to COVID-19 and remains closed at the time of this publication. This item has been submitted to be reviewed when the program resumes.

