



# SERVICE PARTS LIST

## MOTOR ARM/LOWER GUARD ASSEMBLIES

BULLETIN NO.

54-40-2750

SPECIFY CATALOG NO. AND SERIAL NO. WHEN ORDERING PARTS

REVISED BULLETIN

DATE

### M18™ FUEL™ 7.25" MITER SAW

April 2023

CATALOG NO. 2733-20

SERIAL NUMBER

J04A

WIRING INSTRUCTION

00 0

#### EXAMPLE:

Component Parts (Small #) Are Included When Ordering The Assembly (Large #).

#### SERVICE TABLE OF CONTENTS

Page 1	Motor Arm/Lower Guard Assemblies
Page 2	Motor/Handle/Electronics Assemblies
Page 3	Bevel Arm/Slide Assemblies
Page 4	Table Assembly
Page 5	Base Assembly
Page 6	Lubrication
Page 7	Wiring Diagram

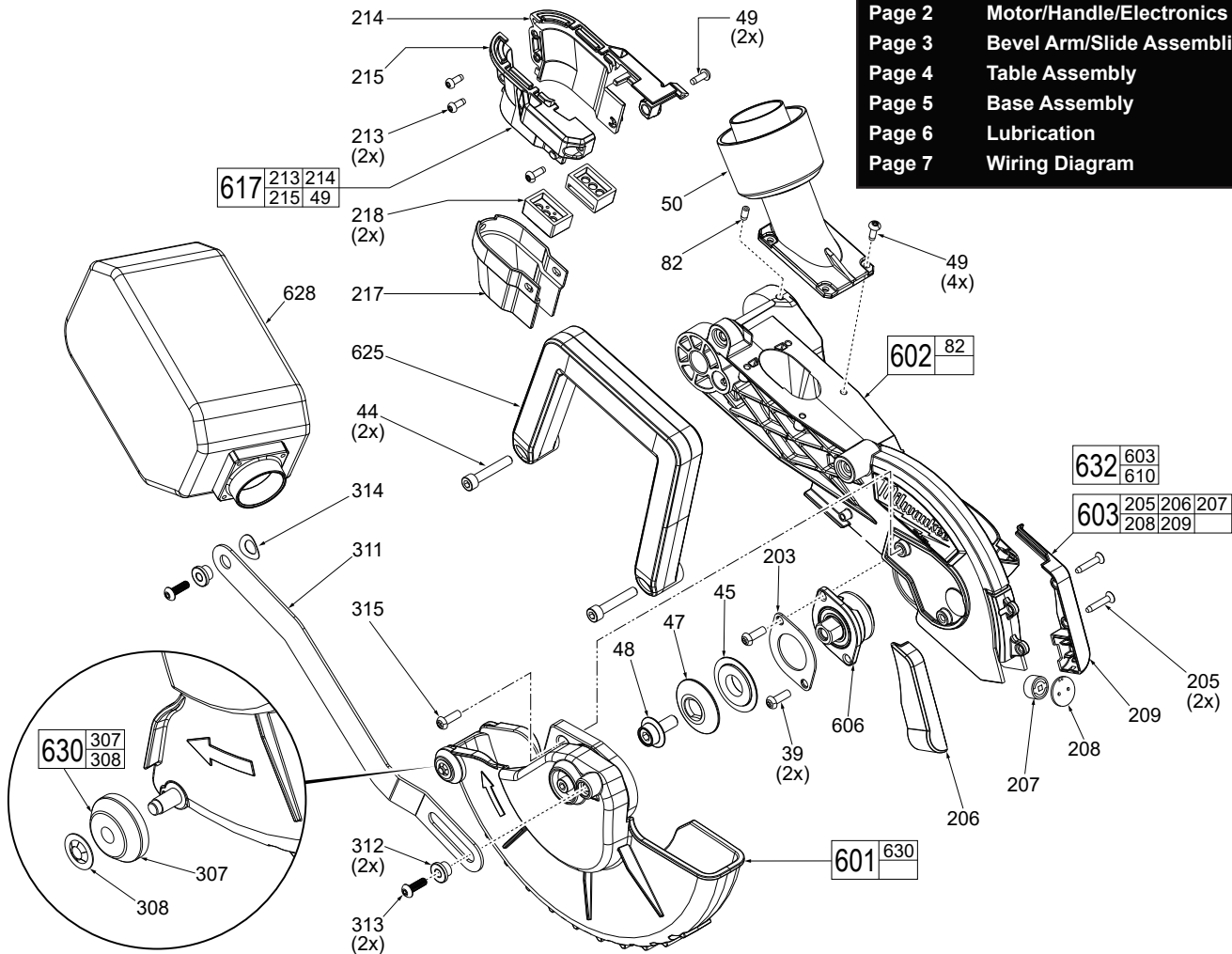

FIG.	PART NO.	DESCRIPTION OF PART	NO REQ.
39	06-81-1705	M5 x 10mm Flat Hd. T-25 Mach. Screw	(2)
44	06-75-1280	Hex Socket Screw	(2)
45	43-34-0132	Inner Blade Flange	(1)
47	43-34-0142	Outer Blade Flange	(1)
48	45-04-0410	LH 6mm Hex Blade Screw	(1)
49	06-82-0225	M4 x 12mm Pan Hd. T-20 Mach. Screw	(6)
50	31-15-0276	Dust Chute Exhaust	(1)
82	06-83-0985	Set Screw	(1)
203	44-66-1075	Bearing Retaining Plate	(1)
205	06-82-0235	M4 x 22mm Pan Hd. T-20 ST Screw	(2)
206	-----	Shadow Line Housing - Left	(1)
207	44-06-0021	Shadow Line Lens	(1)
208	14-20-0102	Shadow Line	(1)
209	-----	Shadow Line Housing - Right	(1)
213	06-82-0240	M4 x 10mm Pan Hd. T-20 ST Screw	(2)
214	-----	Dust Chute Housing - Left	(1)
215	-----	Dust Chute Housing - Right	(1)
217	42-38-0285	Dust Boot	(1)
218	44-06-0107	Cover Block	(2)
307	-----	Guard Roller	(2)
308	-----	Retaining Clip	(2)
311	44-14-0018	Guard Link Arm	(1)
312	42-40-0936	Linkage Bushing	(2)
313	05-81-0817	M5 x 20mm Pan Hd. T-25 Mach. Screw	(2)

FIG.	PART NO.	DESCRIPTION OF PART	NO REQ.
314	45-88-7104	Wave Washer	(1)
315	05-81-0418	M5 x 12mm Pan Hd. T-25 Mach. Screw	(2)
601	14-32-0250	Lower Guard Assembly	(1)
602	14-38-0695	Motor Arm Assembly	(1)
603	-----	Shadow Line Kit (see kit 632)	(1)
606	38-50-2733	Spindle Assembly	(1)
617	31-44-0897	Dust Chute Housing Kit	(1)
625	31-44-1121	Carrying Handle Assembly	(1)
628	42-16-0625	Dust Bag Assembly	(1)
630	14-46-0096	Guard Roller Kit (Set of One)	(2)
632	42-86-0155	Connector Kit	(1)

CRITICAL SCREW TORQUE SPECIFICATIONS				
FIG.	PART NO.	WHERE USED	SEAT TORQUE	
			(kgf-cm)	(lb-in)
39	06-81-1705	Brg. Retaining Plate	30-40	26-34
205	06-82-0235	Shadow Line Hsg.	10-15	8-13



# SERVICE PARTS LIST

BULLETIN NO.  
54-40-2750

MOTOR/ELECTRONICS/ HANDLE ASSEMBLIES

SPECIFY CATALOG NO. AND SERIAL NO. WHEN ORDERING PARTS		REVISED BULLETIN	DATE
<b>M18™ FUEL™ 7.25" MITER SAW</b>			
CATALOG NO.	<b>2733-20</b>	SERIAL NUMBER	<b>J04A</b>
		WIRING INSTRUCTION	

**00** EXAMPLE:  
Component Parts (Small #) Are Included  
When Ordering The Assembly (Large #).

FIG.	PART NO.	DESCRIPTION OF PART	NO REQ.
23	06-82-0220	M4 x 12.7mm Pan Hd. T-20 ST Screw	(1)
49	06-82-0225	M4 x 12mm Pan Hd. T-20 Mach. Screw	(4)
227	05-81-0411	M5 x 12mm Pan Hd. T-25 Mach. Screw	(2)
233	-----	Motor Insulator - Left	(1)
234	-----	Motor Insulator - Right	(1)
235	06-82-0245	M3 x 14mm Pan Hd. T-10 ST Screw	(6)
236	06-82-0250	M4 x 18mm Pan Hd. T-20 ST Screw	(9)
237	-----	Handle Top	(1)
240	23-66-0044	On-Off Switch with Terminal Screws	(1)
241	-----	Handle Bottom	(1)
242	-----	Housing - Left	(1)
242a	12-20-0113	Service Nameplate	(1)
243	05-74-1010	M5 x 15mm Pan Hd. T-25 ST Mach. Scr.	(2)
244	-----	Housing - Right	(1)
245	05-81-0812	M5 x 15mm Pan Hd. T-25 ST Mach. Scr.	(4)
253	06-82-0255	M4 x 24mm Pan Hd. ST T-20 Screw	(2)
604	16-01-2733	Rotor Assembly	(1)
605	31-50-2733	Motor Insulator Kit	(1)
607	31-44-0521	Housing Service Kit	(1)
610	-----	Electronics Assembly (see kit 632)	(1)
624	31-01-0004	LED Button Assembly	(1)
626	31-44-1119	Main Handle Kit	(1)
627	31-92-0211	Trigger Paddle Assembly	(1)
632	42-86-0155	Connector Kit	(1)

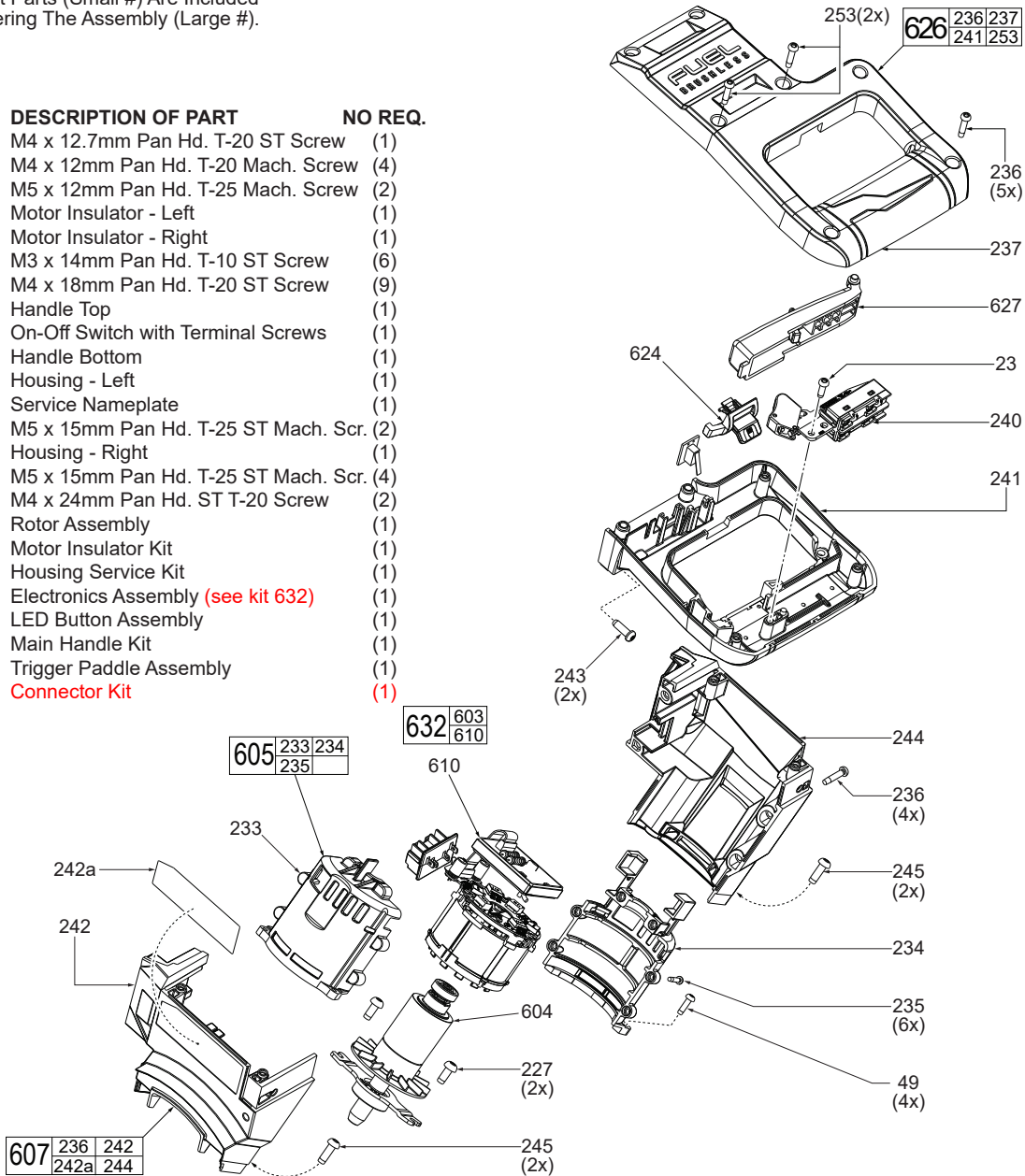

### CRITICAL SCREW TORQUE SPECIFICATIONS

FIG.	PART NO.	WHERE USED	SEAT TORQUE	
			(kgf-cm)	(lb-in)
49	06-82-0225	Motor Insulator	8-10	7-8
227	05-81-0411	Rotor Breaing Plate	30-40	26-34
235	06-82-0245	Motor Insulator	8-12	7-10



# SERVICE PARTS LIST

## BEVEL HUB / RAIL ASSEMBLIES

BULLETIN NO.

54-40-2750

SPECIFY CATALOG NO. AND SERIAL NO. WHEN ORDERING PARTS

REVISED BULLETIN

DATE

### M18™ FUEL™ 7.25" MITER SAW

CATALOG NO. 2733-20

SERIAL NUMBER J04A

WIRING INSTRUCTION

**00** EXAMPLE:  
Component Parts (Small #)  
Are Included When Ordering  
The Assembly (Large #).

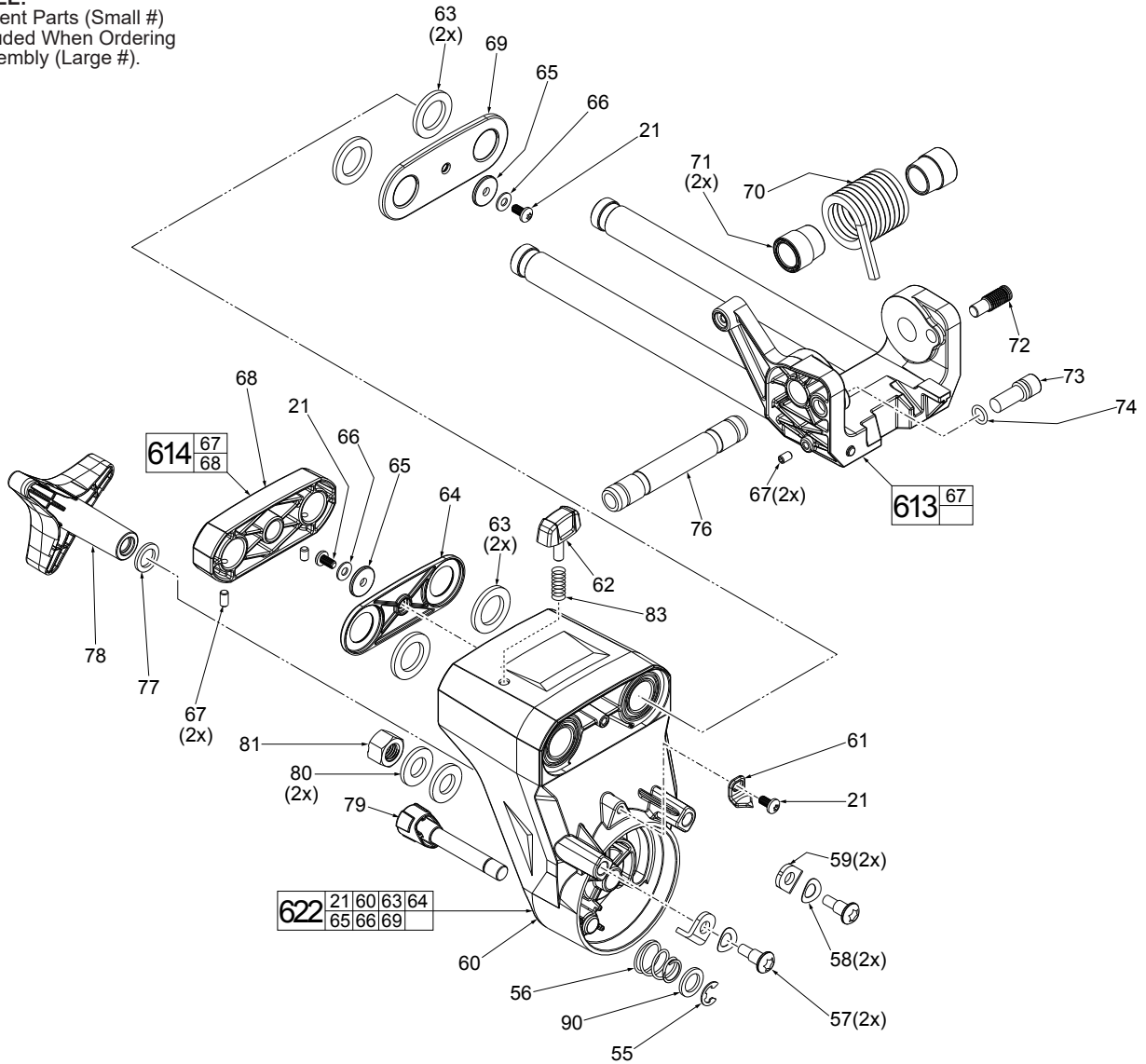

FIG.	PART NO.	DESCRIPTION OF PART	NO REQ.
21	05-81-0164	M4 x 10mm Pan Hd. T-20 Mach. Screw	(3)
55	34-60-0087	Retaining Ring	(1)
56	40-50-0143	Conical Spring	(1)
57	45-04-0735	Shoulder Screw	(2)
58	45-88-0168	Wave Washer	(2)
59	45-52-0045	Bevel Stop	(2)
60	-----	Bevel Arm	(1)
61	44-72-0120	Bevel Pointer	(1)
62	44-20-0652	Lock Knob	(1)
63	45-06-0235	Felt Seal	(4)
64	42-92-1521	Back Bearing Cover	(1)
65	45-88-1701	Buffer Pad	(2)
66	45-88-1731	Washer	(2)
67	06-83-0980	Set Screw	(4)
68	-----	Rail Clamp	(1)
69	42-92-1522	Front Bearing Cover	(1)
70	40-50-0196	Axle Spring	(1)
71	42-40-0194	Pivot Spring Bushing	(2)
72	05-89-0521	Stop Screw	(1)
73	44-60-0003	Down Lock Pin	(1)
74	34-40-0251	O-Ring	(1)
76	42-12-0222	Bevel Axle	(1)
77	45-88-1732	Washer	(1)

FIG.	PART NO.	DESCRIPTION OF PART	NO REQ.
78	43-98-0087	Bevel Knob	(1)
79	44-60-0066	Bevel Stop Pin	(1)
80	45-88-1767	Washer	(2)
81	05-59-0145	M12 Hex Nut	(1)
83	40-50-1017	Spring	(1)
90	45-88-2209	Washer	(1)
613	43-70-0075	Arm Hinge/Slide Rail Assembly	(1)
614	42-68-0512	Rail Clamp Assembly	(1)
622	14-29-0062	Bevel Arm Assembly	(1)



# SERVICE PARTS LIST

**BULLETIN NO.**  
**54-40-2750**

## TABLE ASSEMBLY

SPECIFY CATALOG NO. AND SERIAL NO. WHEN ORDERING PARTS		REVISED BULLETIN	DATE
<b>M18™ FUEL™ 7.25" MITER SAW</b>			
<b>CATALOG NO.</b>	<b>2733-20</b>	<b>SERIAL NUMBER</b>	<b>J04A</b>
		WIRING INSTRUCTION	

**00** **EXAMPLE:**  
Component Parts (Small #)  
Are Included When Ordering  
The Assembly (Large #).

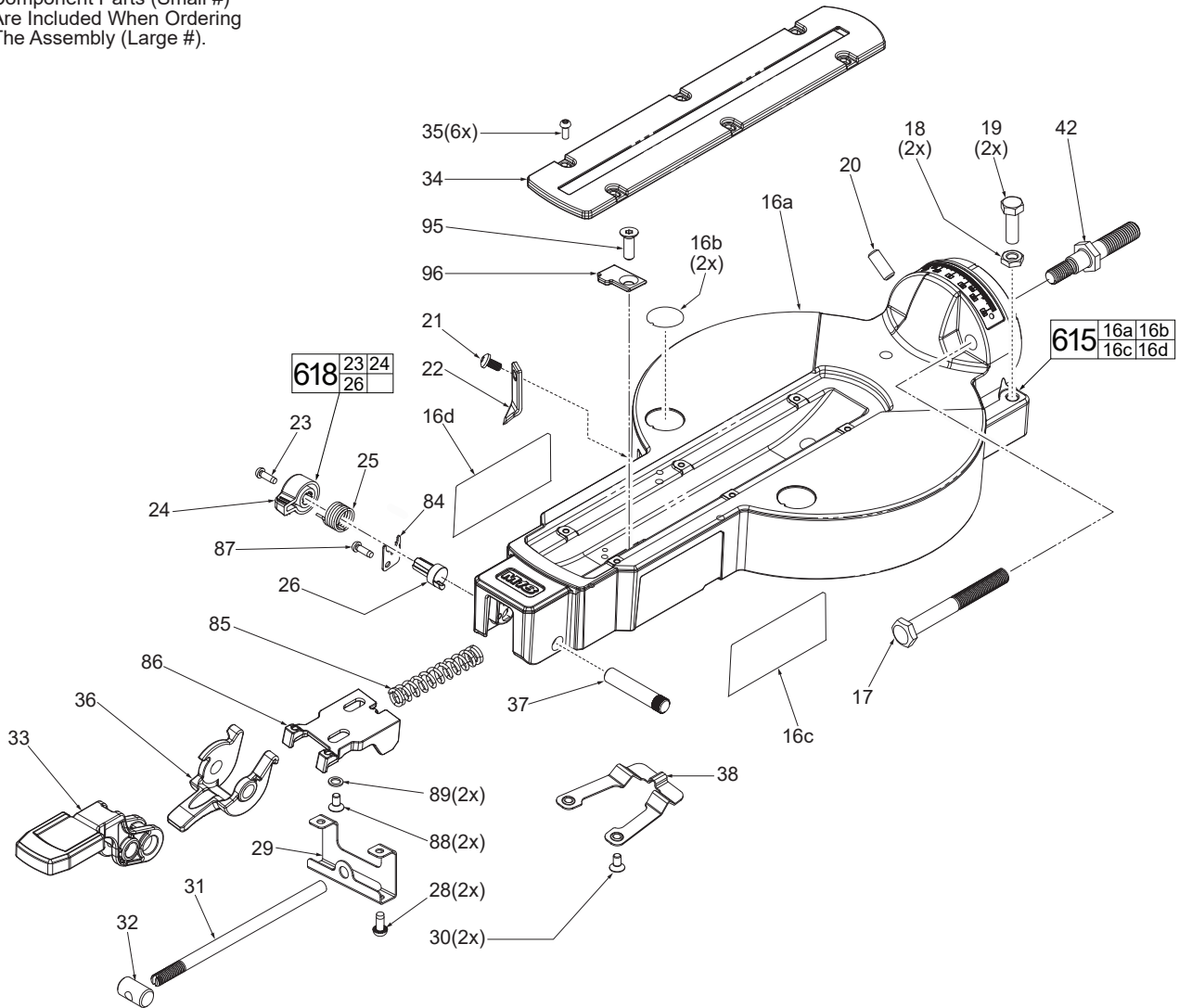

FIG.	PART NO.	DESCRIPTION OF PART	NO REQ.
16a	-----	Table with Bevel Scale	(1)
16b	10-20-2239	'No Hands' Warning Label	(2)
16c	10-20-1404	'Slide Away' Warning Label-Right	(1)
16d	10-20-1400	'Miter Detent Override' Warning Label-Left	(1)
17	06-14-0032	Hex Bolt	(1)
18	05-55-0050	Hex Nut	(2)
19	06-14-0034	Hex Bolt	(2)
20	06-83-0975	Set Screw	(1)
21	05-81-0164	M4 x 10mm Pan Hd. T-20 Mach. Screw	(1)
22	44-72-0115	Miter Pointer	(1)
23	06-82-0220	M4 x 12.7mm Pan Hd. T-20 Screw	(1)
24	-----	Knob	(1)
25	40-50-0088	Torsion Spring	(1)
26	-----	Knob Hub	(1)
28	05-81-0167	M4 x 10mm Pan Hd. T-20 Mach. Screw	(2)
29	44-66-0223	Spring Plate	(1)
30	05-74-1015	Screw	(2)
31	44-94-0271	Miter Lock Rod	(1)
32	44-60-0063	Lock Rod Pivot Nut	(1)
33	43-62-1053	Miter Lock Handle	(1)
34	44-66-0242	Kerf Plate	(1)
35	05-78-0905	M4 x 10mm Pan Hd. T-20 Screw	(6)
36	45-72-0091	Detent Release Trigger	(1)
37	44-60-0064	Handle Pivot Pin	(1)

FIG.	PART NO.	DESCRIPTION OF PART	NO REQ.
38	40-50-1021	Detent Spring	(1)
42	45-58-0135	Bevel Stud	(1)
84	44-66-0282	Retaining Plate	(1)
85	40-50-0086	Detent Slide Spring	(1)
86	44-66-0007	Detent Slider	(1)
87	06-82-0230	M4 x 6mm Screw	(1)
88	05-78-0915	M4 x 8mm Screw	(2)
89	45-88-2208	Washer	(2)
95	05-80-0520	Flat Head Machine Screw	(1)
96	44-66-0291	Plate	(1)
615	28-06-1037	Table Assembly	(1)
618	44-20-0237	Miter Override Lock Assembly	(1)

CRITICAL SCREW TORQUE SPECIFICATIONS				
FIG.	PART NO.	WHERE USED	SEAT TORQUE	
			(kgf-cm)	(lb-in)
30	05-74-1015	Detent Spring	60-70	50-60
42	45-58-0135	Table Assembly	250-300	217-260



# SERVICE PARTS LIST

BULLETIN NO.

54-40-2750

**BASE ASSEMBLY**

SPECIFY CATALOG NO. AND SERIAL NO. WHEN ORDERING PARTS

REVISED BULLETIN

DATE

## M18™ FUEL™ 7.25" MITER SAW

CATALOG NO. 2733-20

SERIAL NUMBER

J04A

WIRING INSTRUCTION

**00** EXAMPLE:  
Component Parts (Small #) Are Included  
When Ordering The Assembly (Large #).

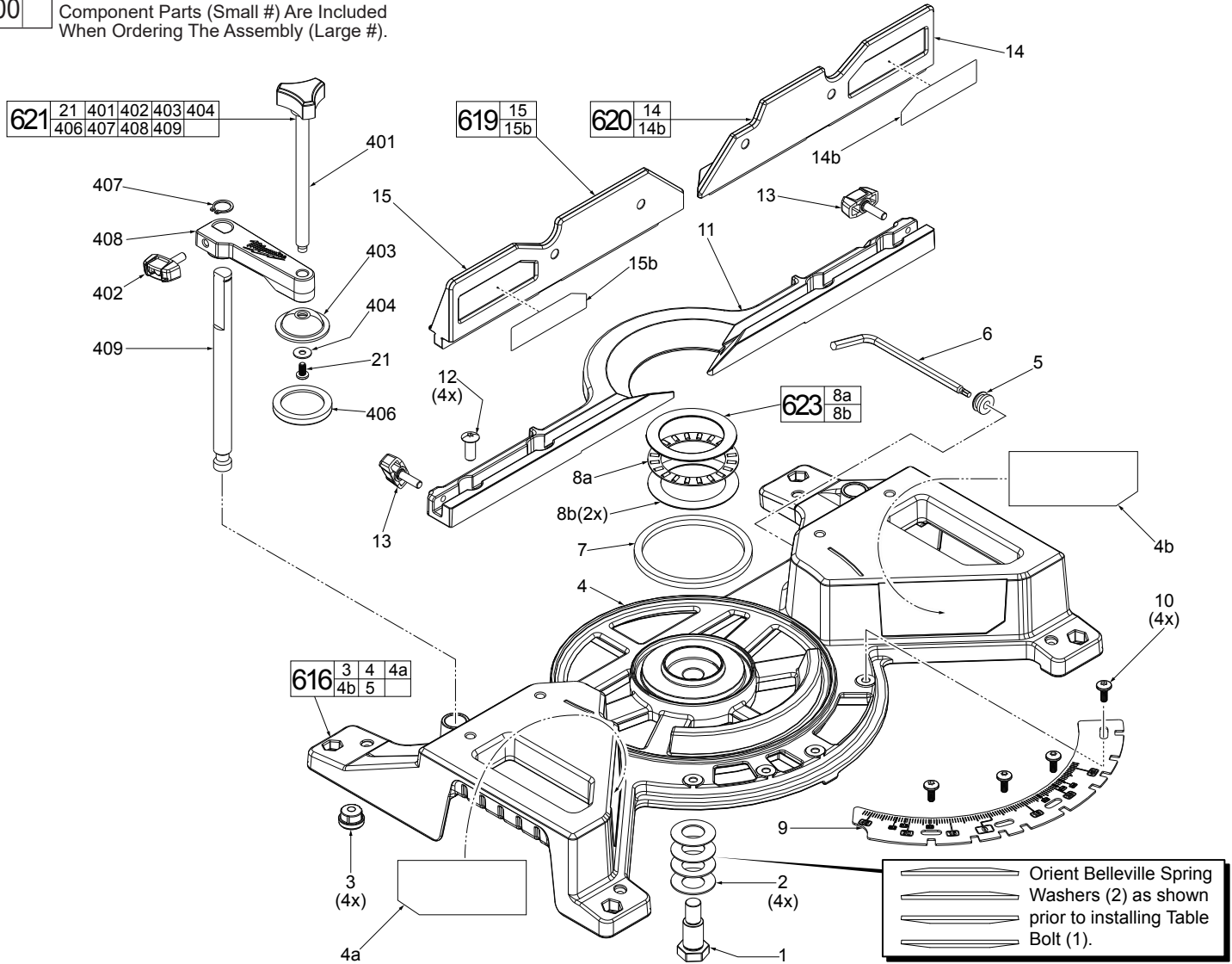

FIG.	PART NO.	DESCRIPTION OF PART	NO REQ.
1	45-08-0471	Table Bolt	(1)
2	40-50-8621	Belleville Spring Washer	(4)
3	44-34-0017	Miter Base Foot	(4)
4	-----	Base	(1)
4a	10-20-1398	Warning Label-Adjusting Bevel Angle	(1)
4b	10-20-1399	Warning Label-Spanish and French	(1)
5	22-90-0185	Wrench Grommet	(1)
6	49-96-0185	Wrench	(1)
7	45-06-0225	Felt Ring	(1)
8a	-----	Thrust Bearing	(1)
8b	-----	Thrust Washer	(2)
9	42-92-1156	Detent Plate/Scale	(1)
10	05-89-0533	M5 x 13mm Pan Hd. T-25 Screw	(4)
11	28-35-0125	Fixed Fence	(1)
12	05-81-0149	M8 x 25mm Pan Hd. T-30 Mach. Screw	(4)
13	43-98-0046	Fence Lock Knob	(2)
14	-----	Sliding Fence - Right	(1)
14b	10-20-1397	Warning Label-Adjust Fence, Right	(1)
15	-----	Sliding Fence - Left	(1)
15b	10-20-1396	Warning Label-Adjust Fence, Left	(1)
21	05-81-0164	M4 x 10mm Pan Hd. T-20 Mach. Screw	(1)
401	43-98-0043	Vise Knob	(1)
402	06-82-0066	Vise Screw	(1)
403	45-16-0115	Clamp Shoe	(1)

FIG.	PART NO.	DESCRIPTION OF PART	NO REQ.
404	45-88-1786	Washer	(1)
406	45-16-0105	Rubber Shoe	(1)
407	34-60-0088	Retaining Ring	(1)
408	42-30-0356	Clamp Body	(1)
409	44-94-0272	Vise Rod	(1)
616	28-06-1121	Base Assembly	(1)
619	28-35-0130	Left Fence Assembly	(1)
620	28-35-0135	Right Fence Assembly	(1)
621	42-38-0087	Material Clamp Assembly	(1)
623	02-80-6002	Thrust Bearing Assembly	(1)

CRITICAL SCREW TORQUE SPECIFICATIONS				
FIG.	PART NO.	WHERE USED	SEAT TORQUE	
			(kgf-cm)	(lb-in)
1	45-08-0471	Base	600-640	520-555
10	05-89-0533	Detent Plate Scale	80-100	69-86



## LUBRICATION NOTES:

### Type 'Y' Grease

No. 49-08-5270, 6oz. tube

When servicing the gears or the Gear Case, 90-95% of the old grease must be removed prior to new grease being added. Clean gear assemblies with a clean, dry cloth.

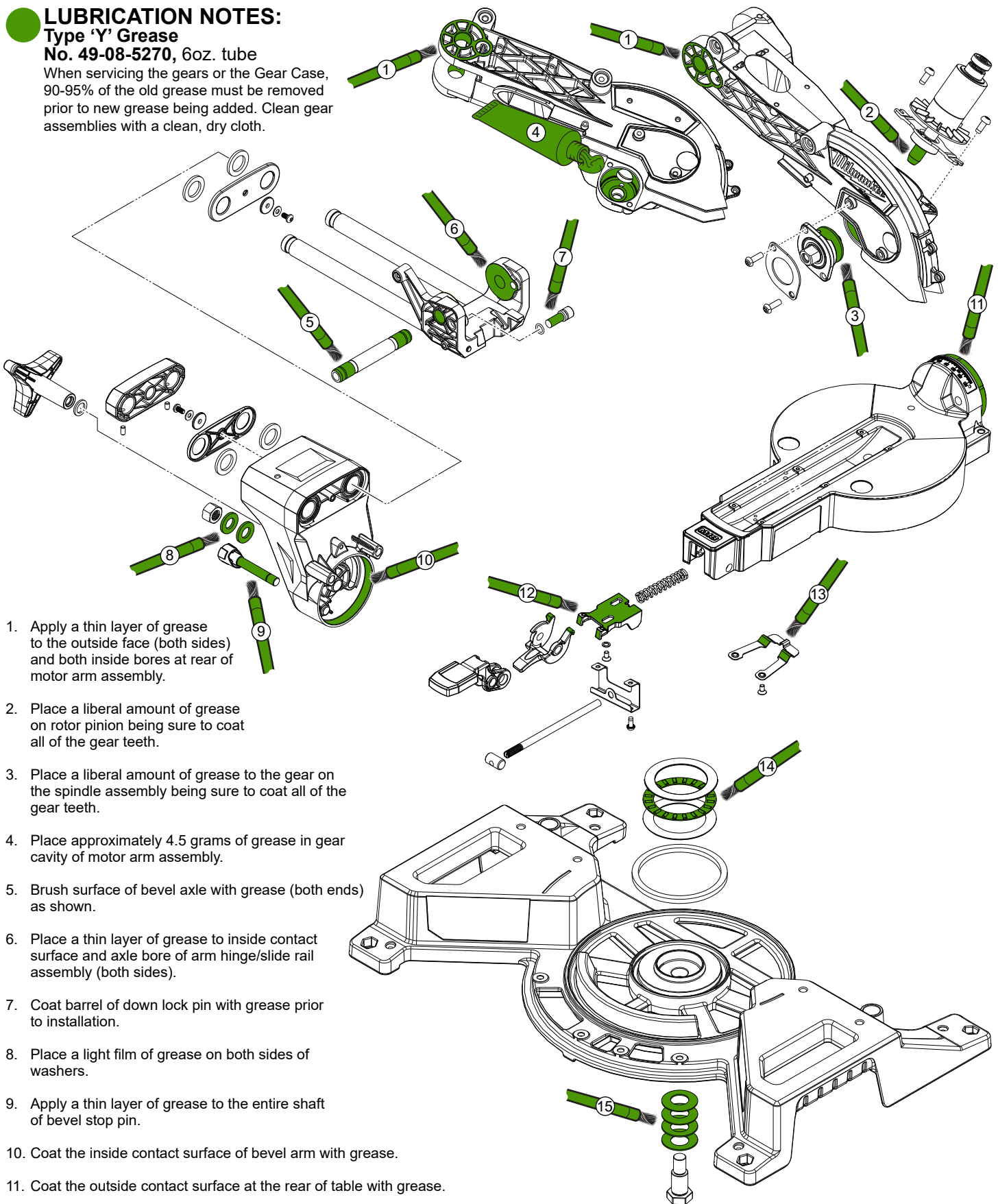

1. Apply a thin layer of grease to the outside face (both sides) and both inside bores at rear of motor arm assembly.
2. Place a liberal amount of grease on rotor pinion being sure to coat all of the gear teeth.
3. Place a liberal amount of grease to the gear on the spindle assembly being sure to coat all of the gear teeth.
4. Place approximately 4.5 grams of grease in gear cavity of motor arm assembly.
5. Brush surface of bevel axle with grease (both ends) as shown.
6. Place a thin layer of grease to inside contact surface and axle bore of arm hinge/slide rail assembly (both sides).
7. Coat barrel of down lock pin with grease prior to installation.
8. Place a light film of grease on both sides of washers.
9. Apply a thin layer of grease to the entire shaft of bevel stop pin.
10. Coat the inside contact surface of bevel arm with grease.
11. Coat the outside contact surface at the rear of table with grease.
12. Apply grease to the contact points of detent release trigger. Add grease to front contact points and top surface of detent slider.
13. Place a dab of grease to the two raised catch tabs on detent spring.
14. Brush both sides of thrust bearing with a heavy layer of grease.
15. Coat all four washers with grease. Be sure to orient washers properly prior to securing with table bolt.

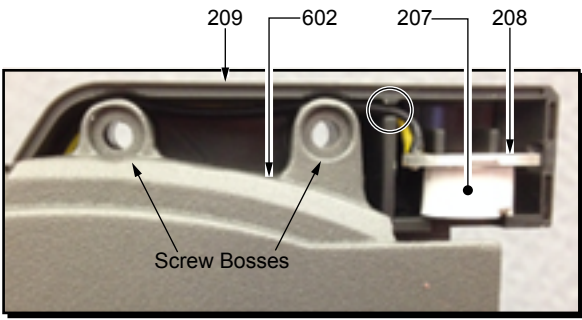

Yellow and black wires from Shadow Line Assembly (208) are to be placed as shown, through wire trap in Right Shadow Line Housing (209). Route wires above screw bosses of Motor Arm Assembly as shown. Press wires along channel on the Motor Arm Assembly (602) and through hole in Left Housing (242). Secure wires with Left Shadow Line Housing (206) and two Screws (205).

Connect male terminal of Shadow Line Assembly to female terminal of PCBA and trap wires as shown in illustration below.

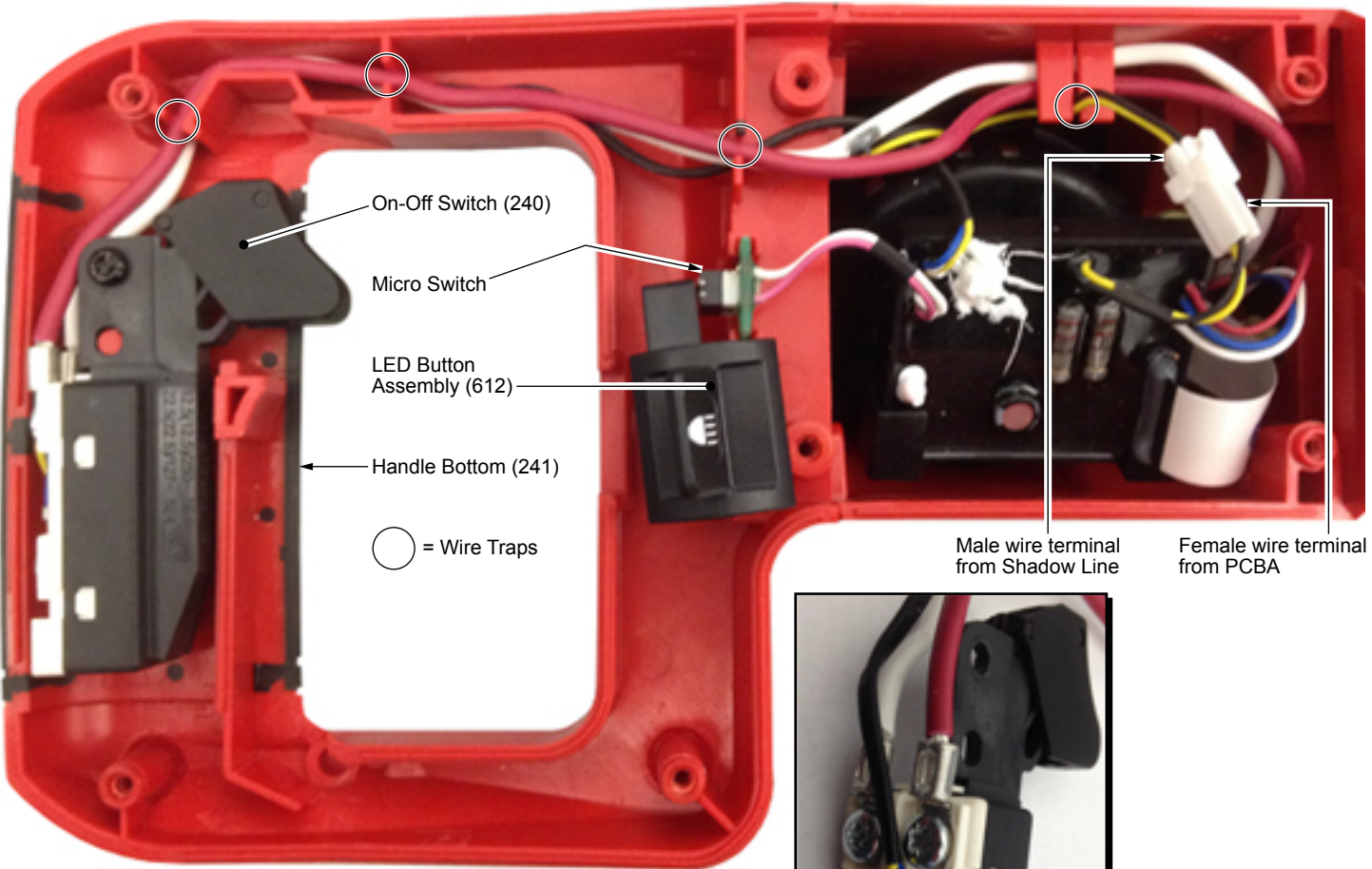
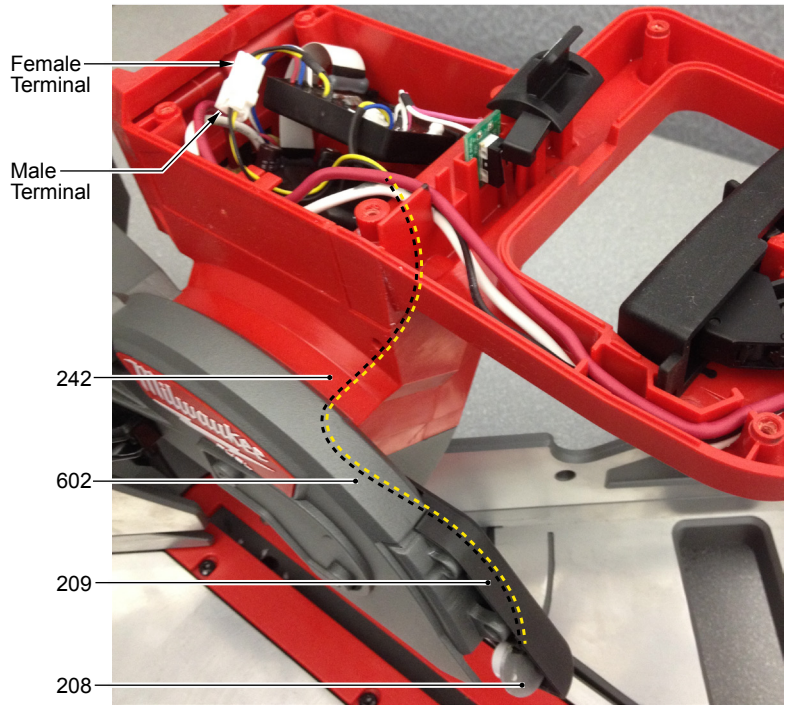

Male wire terminal from Shadow Line

Female wire terminal from PCBA



**On-Off Switch Wiring**

**NOTE:**  
The orientation of the ring terminals is barrel side out. Screw torque is 11-13 kg-cm (9-12 in-lbs).

**AS AN AID TO REASSEMBLY, TAKE NOTICE OF WIRE ROUTINGS AND POSITION IN WIRE GUIDES AND TRAPS WHILE DISMANTLING TOOL.**

**BE SURE ALL ELECTRICAL COMPONENTS ARE FIRMLY AND SQUARELY SEATED IN HANDLE CAVITIES.**

**BE CAREFUL AND AVOID PINCHING WIRES BETWEEN THE HANDLE HALVES BY TUCKING WIRES COMPLETELY DOWN IN TRAPS AND CHANNELS WHEN ASSEMBLING.**

**PRIOR TO INSTALLING A BATTERY, CHECK FOR PROPER FUNCTIONALITY OF SWITCHES, SLIDES AND BUTTONS AFTER HOUSINGS AND HANDLES ARE SECURE.**

**INSTALL BATTERY AND VERIFY THE PROPER OPERATION OF TOOL.**