



SERVICE PARTS LIST

BULLETIN NO.
54-49-2700

SPECIFY CATALOG NO. AND SERIAL NO. WHEN ORDERING PARTS		REVISED BULLETIN	DATE
M18™ FUEL™ HEDGE TRIMMER			Sept. 2021
CATALOG NO. 2726-20	STARTING SERIAL NO. H34A	WIRING INSTRUCTION See Page 3	

EXAMPLE:
Component Parts (Small #)
Are Included When Ordering
The Assembly (Large #).

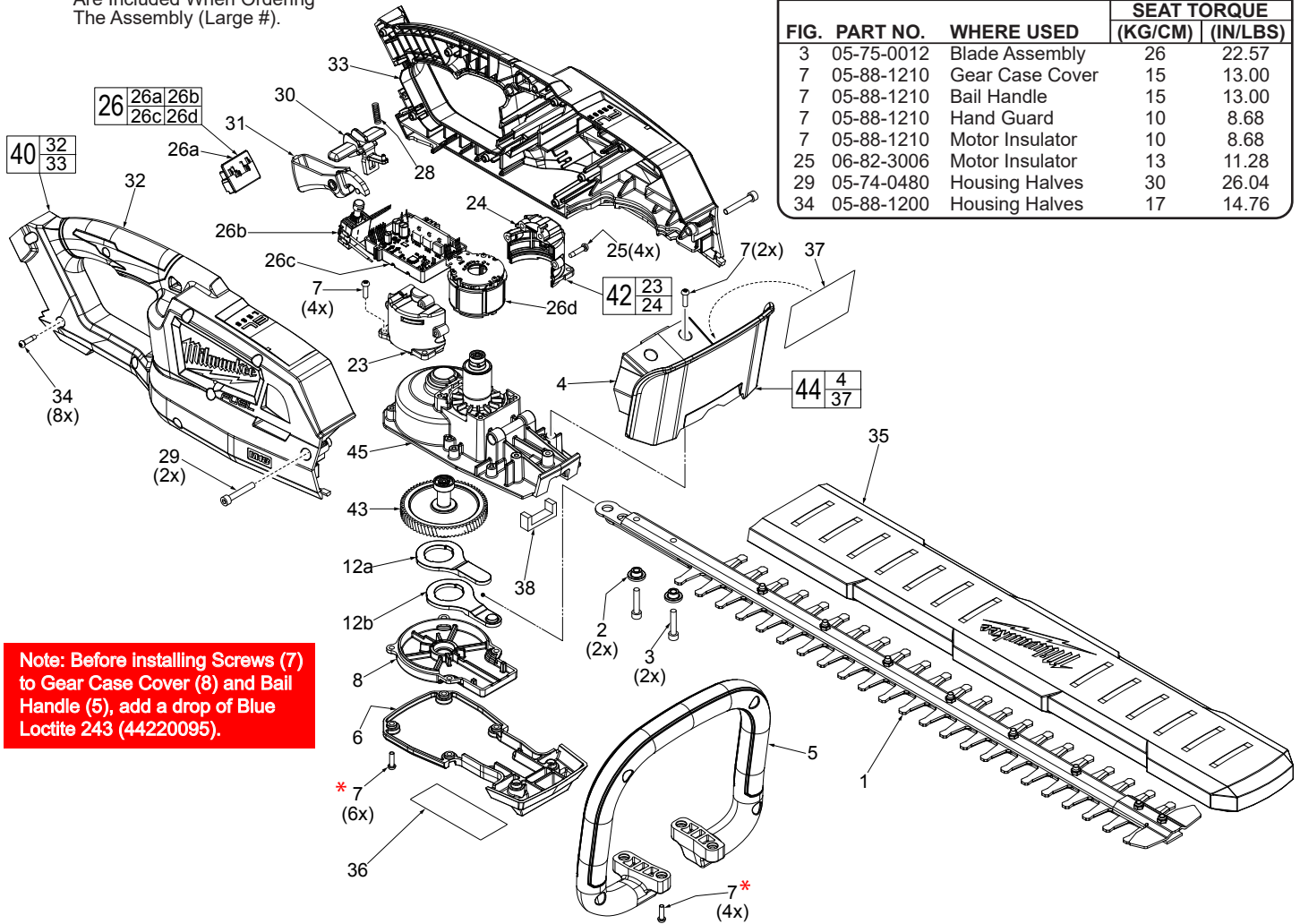

Note: Before installing Screws (7) to Gear Case Cover (8) and Bail Handle (5), add a drop of Blue Loctite 243 (44220095).

SCREW TORQUE SPECIFICATIONS				
FIG.	PART NO.	WHERE USED	SEAT TORQUE	
			(KG/CM)	(IN/LBS)
3	05-75-0012	Blade Assembly	26	22.57
7	05-88-1210	Gear Case Cover	15	13.00
7	05-88-1210	Bail Handle	15	13.00
7	05-88-1210	Hand Guard	10	8.68
7	05-88-1210	Motor Insulator	10	8.68
25	06-82-3006	Motor Insulator	13	11.28
29	05-74-0480	Housing Halves	30	26.04
34	05-88-1200	Housing Halves	17	14.76

FIG.	PART NO.	DESCRIPTION OF PART	NO. REQ.
1	42-26-0023	24" Blade Assembly (Standard)	1
2	42-40-0019	Bushing	2
3	05-75-0012	M5 x 0.8 x 30, 4mm Hex Cap Screw	2
4	-----	Hand Guard	1
5	43-62-0016	Bail Handle	1
6	31-15-0032	Gear Case Cover	1
7	05-88-1210	M4 x 0.7 x 14 Pan Hd. T-20 Machine Screw	16
8	42-92-0009	Gear Cover	1
12a	42-86-0101	Connecting Plate	1
12b	42-86-0101	Connecting Plate	1
23	-----	Right Motor Housing Insulator - Support	1
24	-----	Left Motor Housing Insulator - Cover	1
25	06-82-3006	M4 x 1.4 x 18 Pan Hd. ST T-20 Security Scr	4
26	14-20-0036	Electronic Assembly	1
26a	-----	Battery Connector Block Assembly	1
26b	-----	Switch Assembly	1
26c	-----	PCBA	1
26d	-----	Stator Assembly	1
28	40-50-4520	Lock-Off Spring	1
29	05-74-0480	M5 x 0.8 x 25, 4mm Hex Cap Screw	2
30	42-42-0011	Lock-Off Button	1
31	31-92-0016	Switch Trigger	1
32	-----	Right Housing Assembly - Cover	1
33	-----	Left Housing Assembly - Support	1
34	05-88-1200	M4 x 1.4 x 16 Pan Hd. ST T-15 Screw	8

FIG.	PART NO.	DESCRIPTION OF PART	NO. REQ.
35	49-62-0010	24" Blade Sheath (Standard)	1
36	12-20-0316	Service Nameplate	1
37	10-20-1041	Caution Label	1
38	45-06-0026	Felt Seal	1
40	31-44-2726	Housing Kit	1
42	31-50-2712	Motor Insulator Kit	1
43	14-29-0011	Gear / Crank Shaft Assembly	1
44	43-54-0099	Hand Guard Kit	1
45	14-30-0011	Gear Case / Rotor Assembly	1

FIG. NOTE:
5 Dimples of Bail Handle (5) must face to the front of the tool.
26d Be sure to position the grooves in the Stator Assembly (26b) on the ribs in the inside cavities of Motor Insulator Halves (23,24).
38 See page two for proper location and orientation of Felt Seal (38).
44 Hand Guard Kit (44) must be installed prior to Housing Kit (40) being secured with screws (29).
45 Do not attempt to remove the rotor from the Gear Case / Rotor Assembly (45).

**ALWAYS REMOVE BATTERY PACK
BEFORE PERFORMING ANY
MAINTENANCE OR REPAIRS**

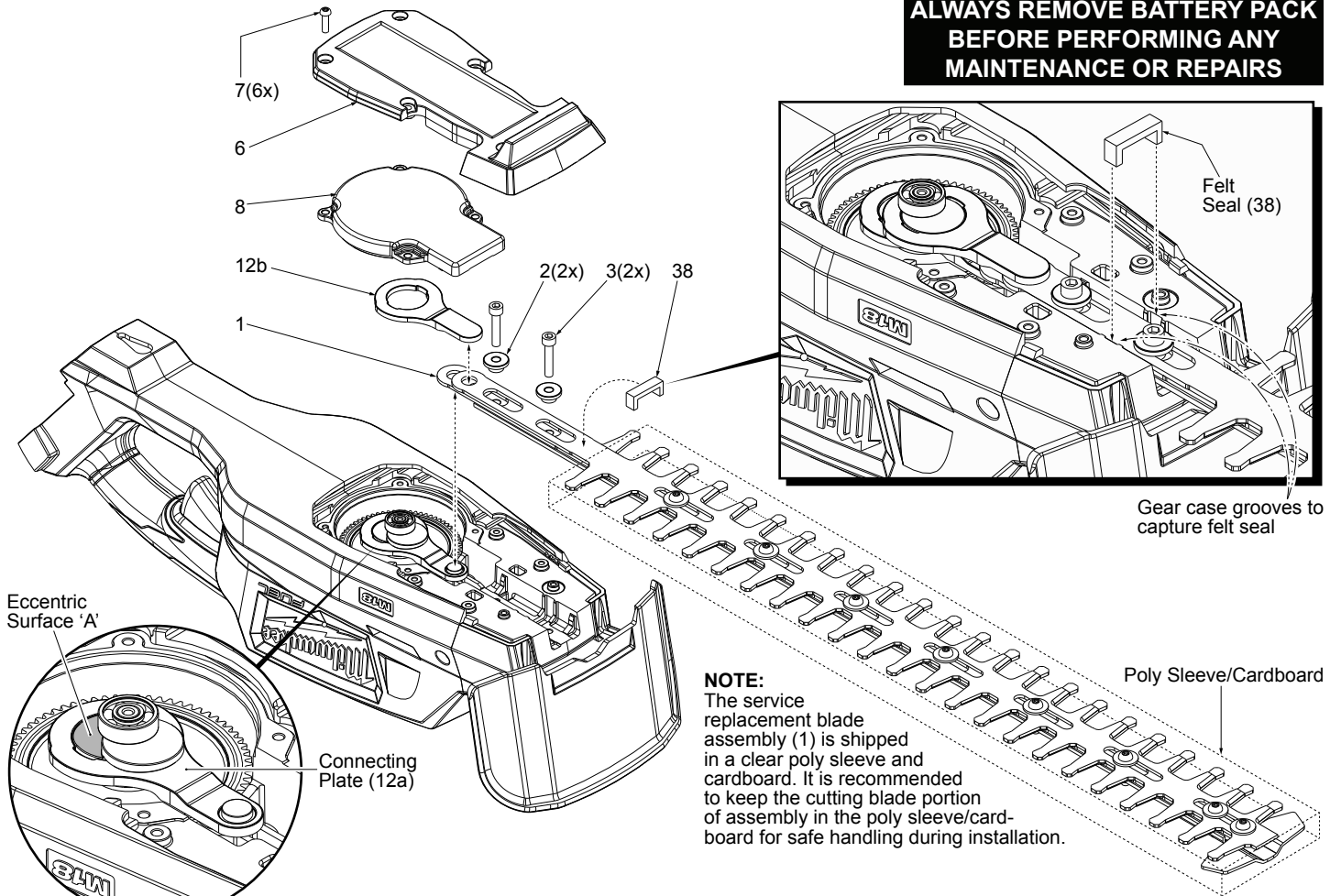

NOTE:
The service replacement blade assembly (1) is shipped in a clear poly sleeve and cardboard. It is recommended to keep the cutting blade portion of assembly in the poly sleeve/cardboard for safe handling during installation.

INSTALLING REPLACEMENT BLADE ASSEMBLY

- **Remove battery pack**
- Be sure top of Connecting Plate (12a) is flush with surface 'A' of the eccentric on the Gear/Crank Shaft Assembly (43).
- Install new Blade Assembly (1) onto connecting plate (12a) as shown by placing the hole of the blade assembly over the lug on the connecting plate.
- **As an aid to keeping the connecting plate (12a) flush to the 'A' surface of the eccentric,** support the tool housing on one end being sure the bottom of the gear case is parallel with the work surface. Place a 3-1/2" wood block on the other end under the tip of the replacement blade assembly, *see illustration below*.
- Place Connecting Plate (12b) over the bearing and onto the eccentric of the Gear/Crank Shaft Assembly (43). Place the lug of connecting plate (12b) into the hole of the blade assembly. **NOTE:** An instrument such as a nail or small screwdriver may have to be inserted into the exhaust vent to rotate the fan so the eccentric can turn and line up the hole with the lug. Be sure eccentric surface 'B' is flush with the top surface of connecting plate (12b).
- Place Felt Seal (38) over the blade assembly. Tuck each end down into grooves on gear case.
- Place a light coating of lubrication onto the Bushings (2) and place onto slots of blade assembly.
- Place a drop of red locking sealant onto the threads of screws (3). Insert screws through the bushings and secure to the gear case.
- Place Gear Cover (8) onto gear case.
- Place Gear Case Cover (6) over gear cover and onto the gear case. Secure with six screws (7).
- Remove plastic cover (if used) from blade assembly. Install battery and check for functionality.

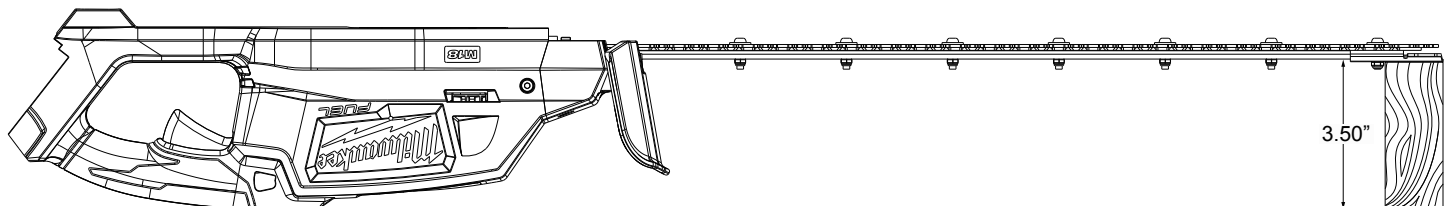

Support the tool body so the bottom of the tool is parallel with the work surface

LUBRICATION
White Lithium Grease

NOTE:

When servicing the tool, 90-95% of the old grease must be removed prior to new grease being added.

- Apply a heavy coat of grease around the perimeter of the gear, being sure to cover all gear teeth (approx. 3 grams).
- Apply a heavy coat of grease to the motor pinion, being sure to cover all the pinion teeth (approximately 3 grams).
- Apply a thick film of grease to the entire connecting rod, including the walls of the ID, (2 pieces).
 Apply a thick coat of grease to the corresponding contact area of the crank shaft (approximately 2 grams).
- Apply a thick coat of grease to the blade assembly where there is contact with the connecting rods (approx. 2 grams).

NOTE: DO NOT over lubricate tool! Too much grease can cause grease discharge through the gear case.

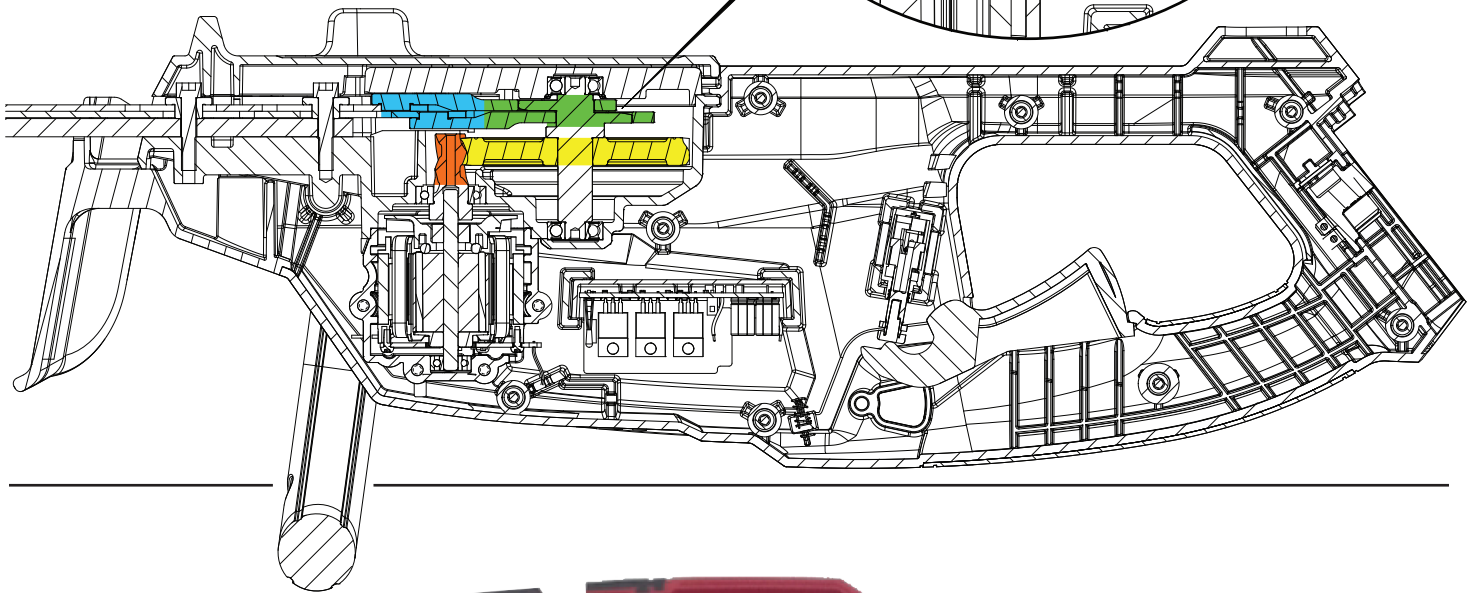
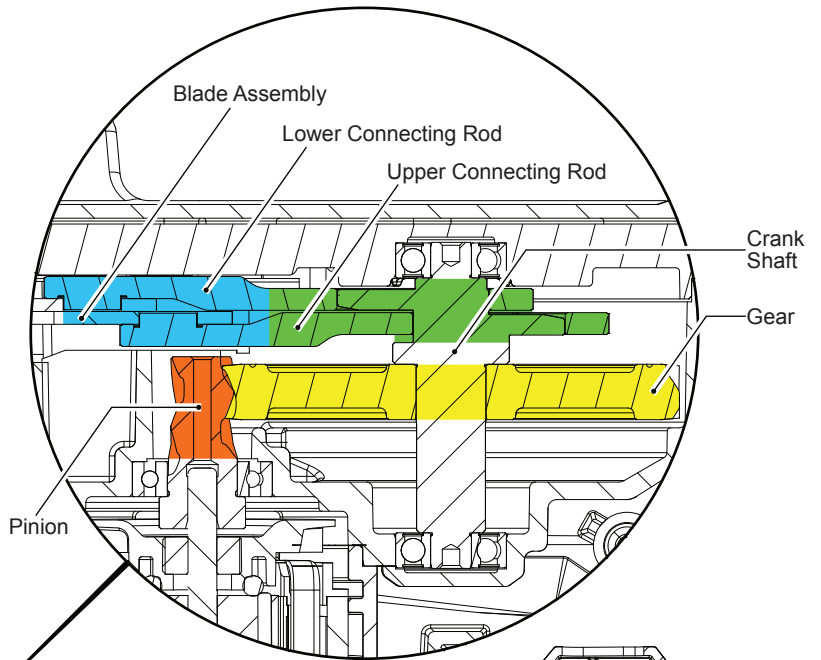

WIRING INSTRUCTION

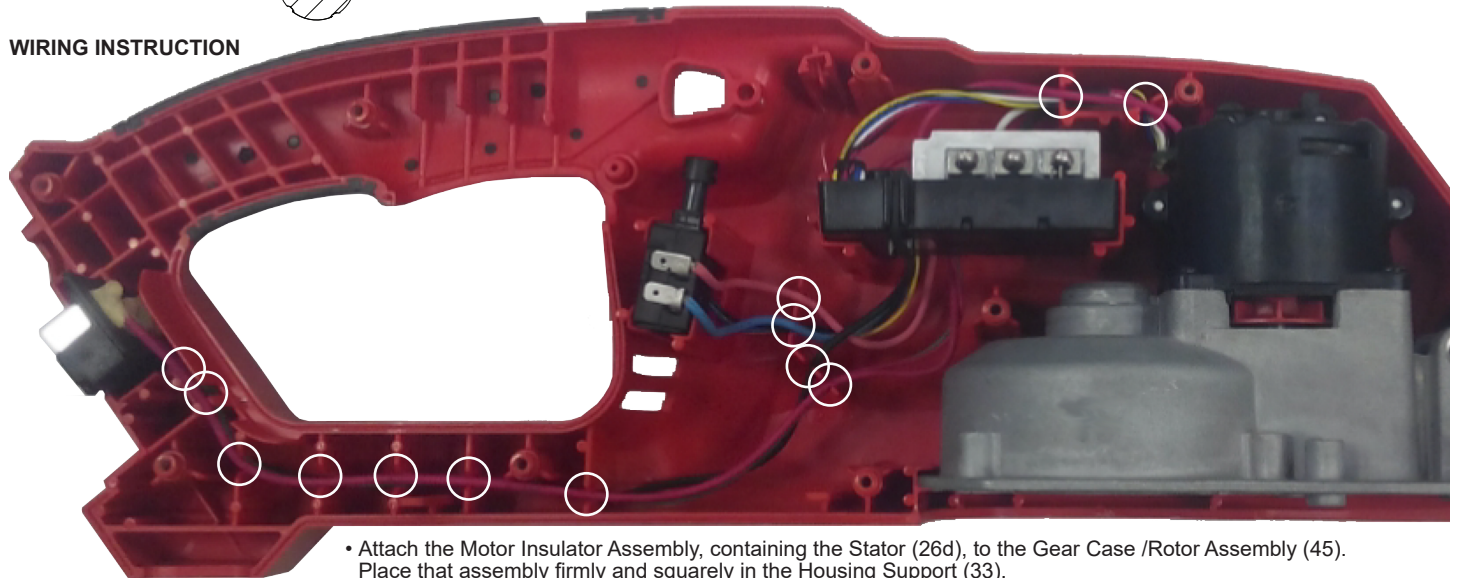

- Attach the Motor Insulator Assembly, containing the Stator (26d), to the Gear Case /Rotor Assembly (45). Place that assembly firmly and squarely in the Housing Support (33).
- Place the PCBA (26c), Switch (26b) and Battery Connector Block Assembly (26a) firmly and squarely in the corresponding cavities in the Housing Support (33).
- Route the wires as shown, being sure to push the wires firmly down into the traps (marked with white circles).
- Return Switch Trigger (31), Lock-Off Button (30) and Spring (28) to the proper location in the Housing Support.
- Carefully install the Hand Guard (44) and Housing Cover (32) onto the Housing Support, checking for interferences.
- Secure the Housing Halves and Hand Guard with eight Screws (34) and two Screws (29).
- Check for the the free movement and proper functionality of the Switch and Lock-Off Button.
- Install battery and check for proper operation of the entire tool.