

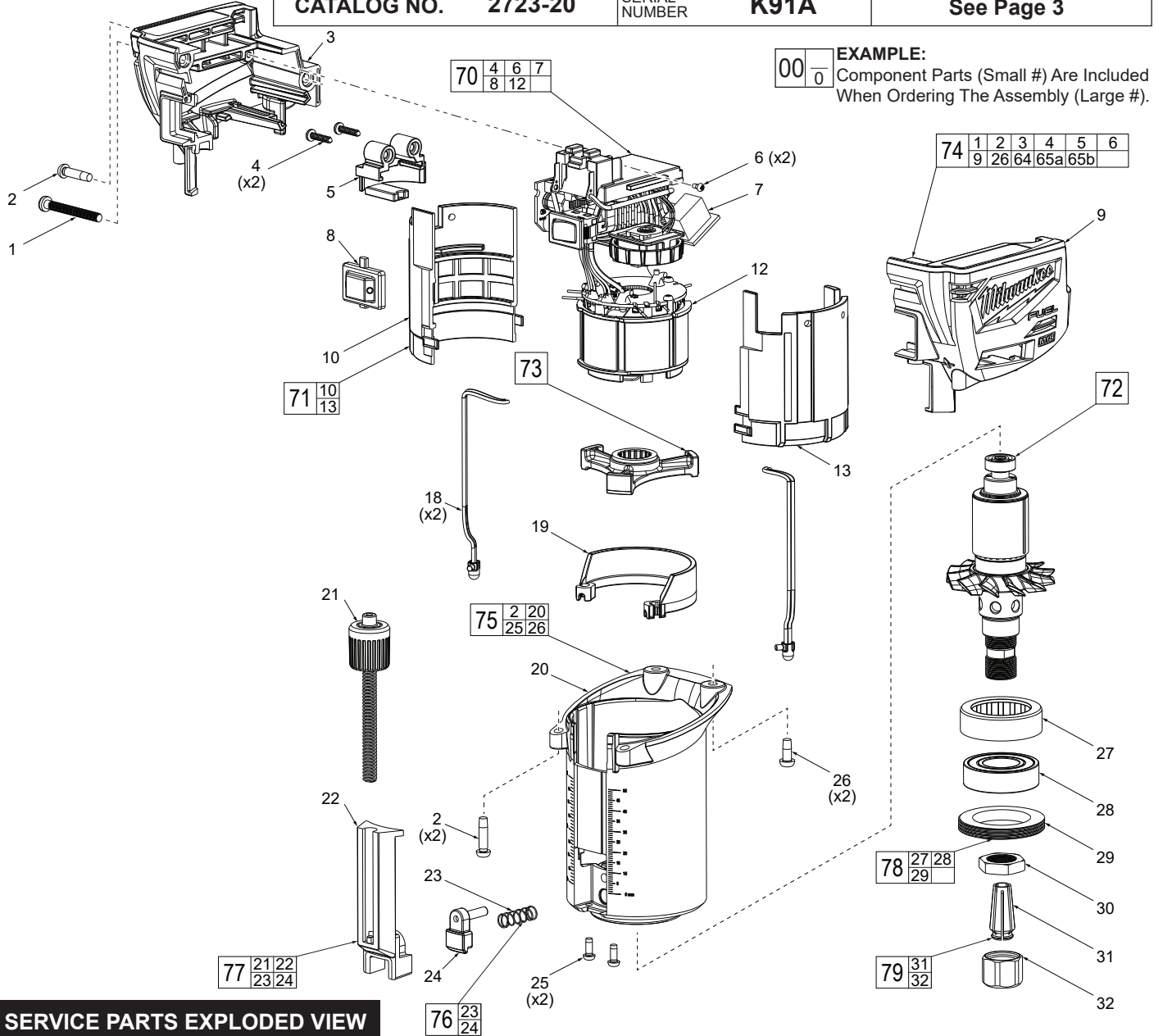

SERVICE PARTS LIST

BULLETIN NO.
54-00-2723

SPECIFY CATALOG NO. AND SERIAL NO. WHEN ORDERING PARTS		REVISED BULLETIN	DATE
M18 FUEL Compact Router			Aug. 2022
CATALOG NO.	2723-20	SERIAL NUMBER	K91A
		WIRING INSTRUCTION See Page 3	



SERVICE PARTS EXPLODED VIEW

FIG.	PART NO.	DESCRIPTION OF PART	QTY.	FIG.	PART NO.	DESCRIPTION OF PART	QTY.
1	05-78-0042	M4 x 0.7 PH T-20 PH Screw	(1)	29	-----	Bearing Retaining Nut	(1)
2	05-81-0066	M4 x 16mm T-15 PH Screw	(3)	30	05-55-0031	9/16" Hex Nut	(1)
3	-----	Housing Cover	(1)	31	43-44-0043	1/4" Collet	(1)
4	05-78-0044	M3 x 1.27mm T-10 PH Screw	(2)	32	48-68-0031	Collet Nut	(1)
5	-----	Speed Dial Clamp Cover	(1)	64	12-20-0216	Service Nameplate (Not Shown)	(1)
6	05-10-0068	M3 x 6mm Torx PH Recess Phillips #2 Screw	(2)	65a	10-20-3114	Warning Label (Not Shown)	(1)
7	-----	PCBA Assembly	(1)	65b	10-20-3116	Warning Label (Not Shown)	(1)
8	42-92-0076	Rubber Switch Cover	(1)	70	14-20-0136	Motor & PCBA Assembly	(1)
9	-----	Housing Support	(1)	71	14-38-0053	Motor Housing Assembly	(1)
10	-----	Motor Housing Support	(1)	72	16-01-0027	Motor Assembly	(1)
12	-----	Motor Stator	(1)	73	45-60-0017	Upper Bearing Assembly	(1)
13	-----	Motor Housing Cover	(1)	74	31-44-0142	Handle Housing Assembly	(1)
18	-----	LED Assembly	(2)	75	42-98-0020	Barrel Assembly	(1)
19	22-09-0024	LED Carrier	(1)	76	14-46-0122	Spindle Assembly	(1)
20	-----	Alloy Outer Housing	(1)	77	44-40-0021	Spindle Lock w/ Knob Assembly	(1)
21	-----	Height Adjustment Knob	(1)	78	14-46-0152	Lower Bearing Assembly	(1)
22	-----	Threaded Rod Support	(1)	79	14-46-0167	1/4" Collet Nut Assembly	(1)
23	-----	Spring	(1)				
24	-----	Spindle Lock Button	(1)				
25	05-81-0071	M3 x 8mm T-10 BH Screw	(2)				
26	05-78-0039	M4 x 10mm T-20 PH Taptite Screw	(2)				
27	23-16-0021	Bearing Insulator	(1)				
28	-----	Ball Bearing	(1)				

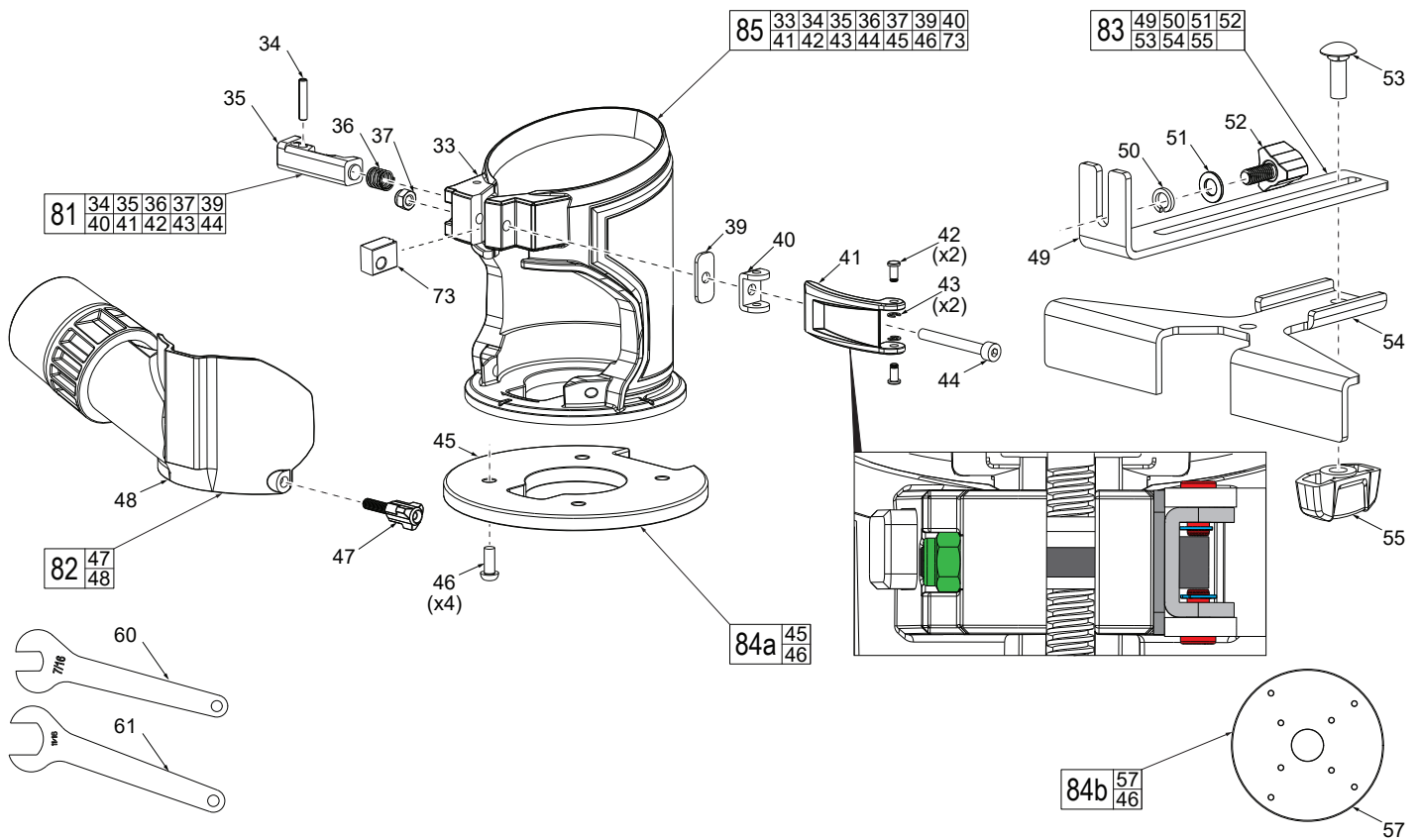

SERVICE PARTS EXPLODED VIEW - continued

FIG.	PART NO.	DESCRIPTION OF PART	QTY.
33	-----	Fixed Base Barrel	(1)
34	-----	Spring Pin	(1)
35	-----	Threaded Capture	(1)
36	-----	Spring	(1)
37	-----	M4 x .7mm Hex Nut	(1)
39	-----	Wear Plate	(1)
40	-----	Locking Yoke	(1)
41	-----	Base Locking Lever	(1)
42	-----	Rivet Pin	(2)
43	-----	E-Ring	(2)
44	-----	M4 x .7mm M 3mm Hex Recess	(1)
45	-----	Standard Subbase Plate	(1)
46	-----	M4 PH Recess Phillips #2 Screw	(4)
47	43-98-0031	Thumb Knob	(1)
48	-----	Dust Extractor Hood	(1)
49	-----	Adjustment Bracket	(1)
50	-----	Spring Washer	(1)
51	-----	Washer	(1)
52	-----	Thumb Knob	(1)

FIG.	PART NO.	DESCRIPTION OF PART	QTY.
53	-----	M6 x 18mm Square Shoulder M Screw	(1)
54	-----	Base Bracket	(1)
55	-----	Thumb Lock	(1)
57	-----	Oversized Subbase Plate	(1)
60	44-60-0115	Open End Wrench (7/16")	(1)
61	49-96-4090	Open End Wrench (11/16")	(1)
73	23-50-0015	Rubber Spacer	(1)
81	14-70-0041	Latch Assembly	(1)
82	22-84-0015	Dust Extraction w/ Knob Assembly	(1)
83	43-98-0091	Edge Guide Assembly	(1)
84a	31-06-0032	Standard Base Assembly	(1)
84b	31-06-0034	Oversized Base Assembly	(1)
85	31-06-0036	Fixed Base Assembly	(1)

FIG. NOTES:
 41,44 Clamping force for the base clamp lever (41) is adjusted with base clamp screw (44). Tighten the screw using 4.3-13.5 lbs. force to close the lever to the locked position. Motor unit must be in base when checking force.

LUBRICATION INSTRUCTIONS

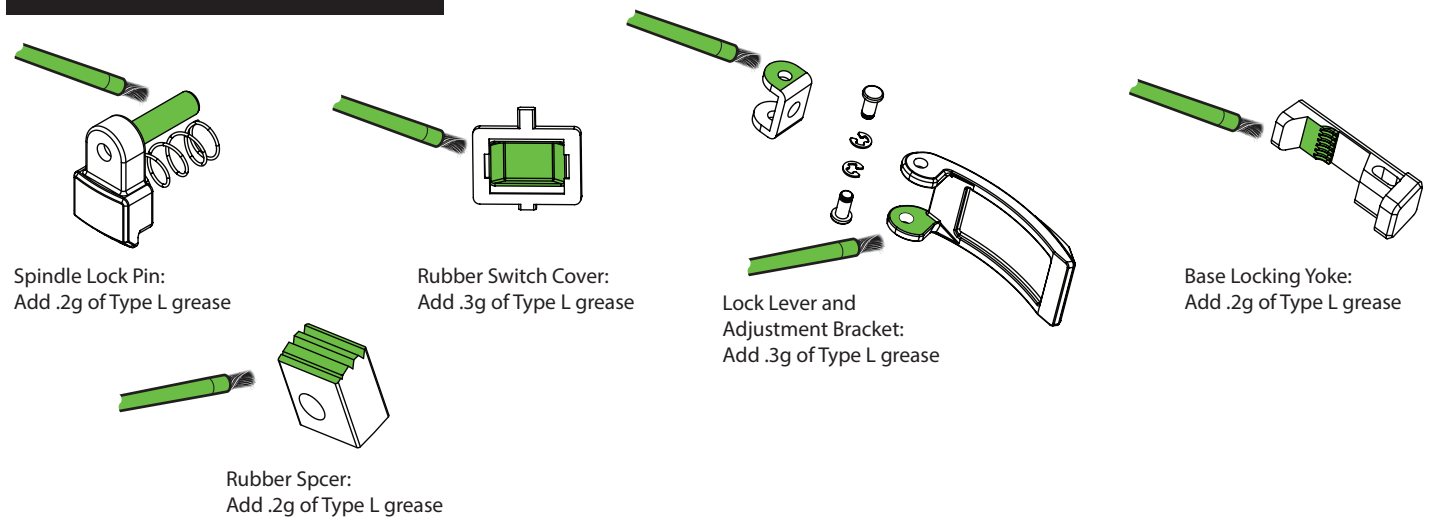

Spindle Lock Pin:
Add .2g of Type L grease

Rubber Switch Cover:
Add .3g of Type L grease

Lock Lever and
Adjustment Bracket:
Add .3g of Type L grease

Base Locking Yoke:
Add .2g of Type L grease

Rubber Spcer:
Add .2g of Type L grease

WIRE ROUTE LAYOUT

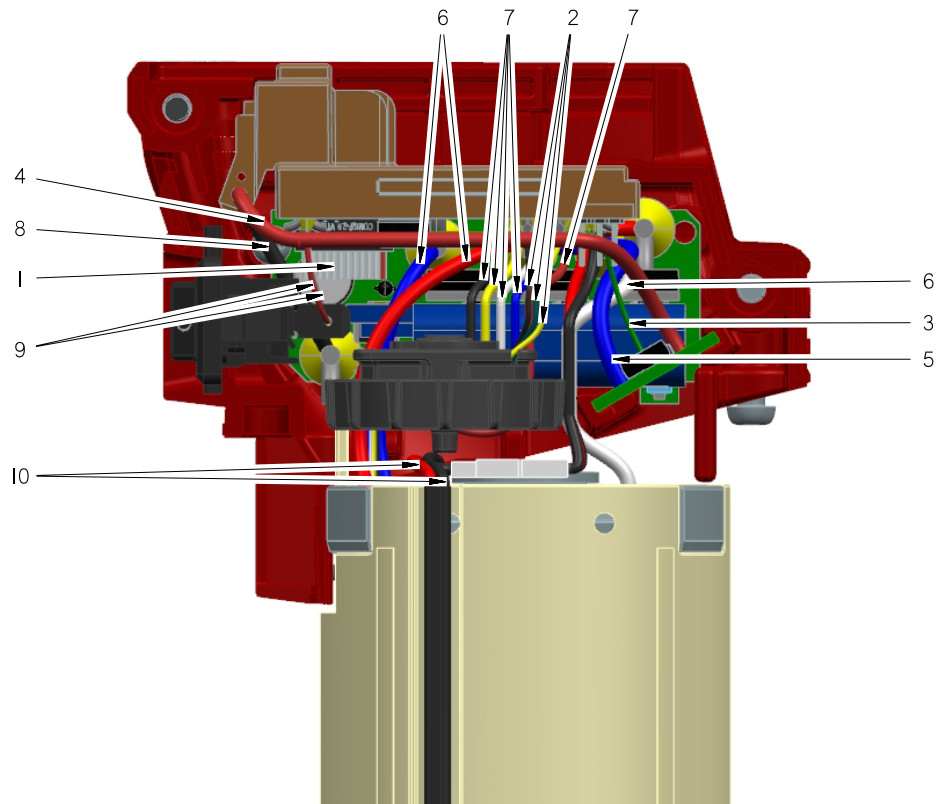
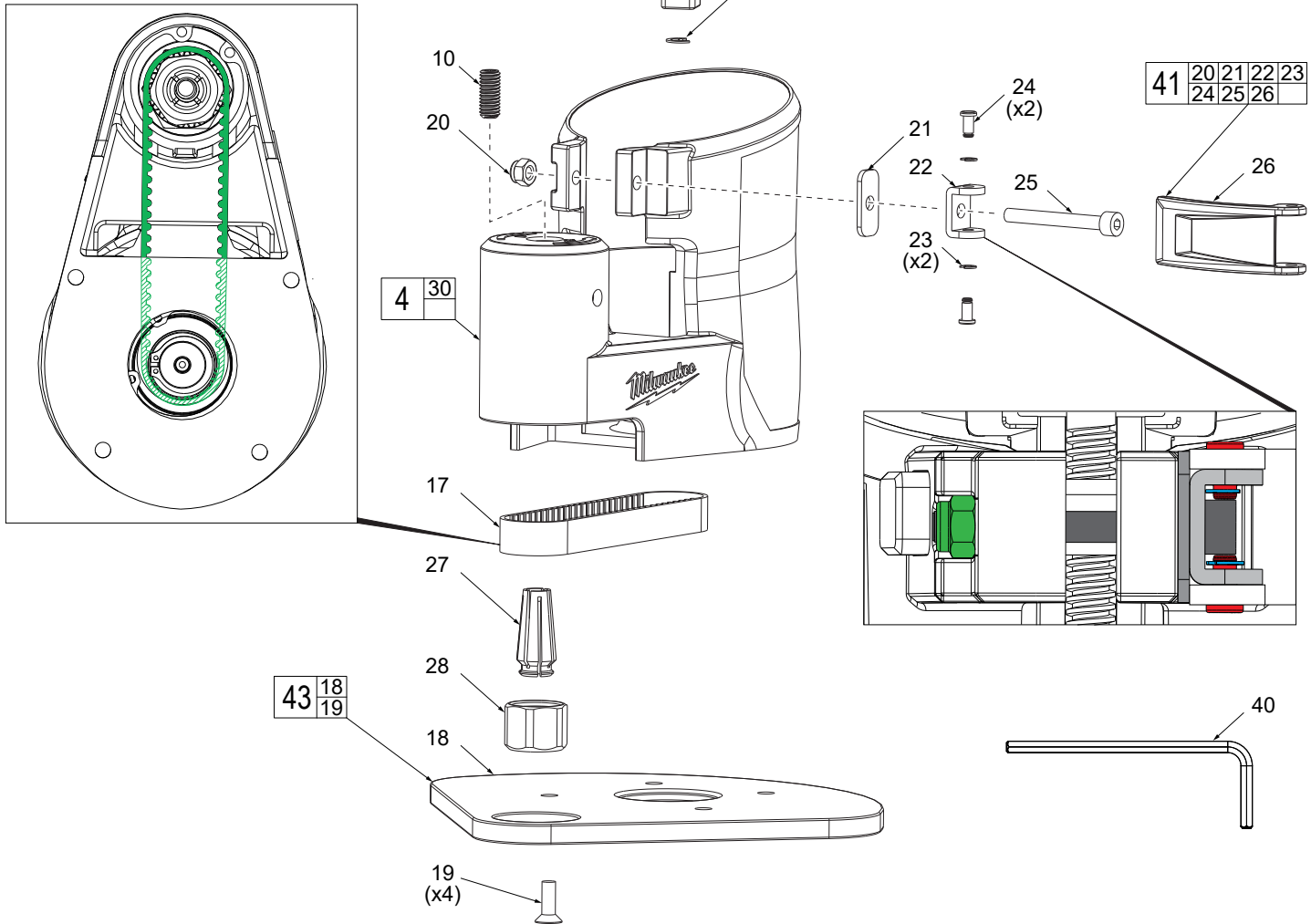

FIG.	DESCRIPTION
1	12 Pin Ribbon Cable Between Power Board and Control Board
2	Wires to Speed Dial Board (Yellow, White and Black)
3	Green Wire to Relay Board
4	Red Wire Between Relay and Control Board
5	Red Wire Between Relay and Power Board
6	Connecting Hall Board to Power Board (Red, White and Blue)
7	Wire Between Hall Board and Control Board
8	Black Wire Between Power Board and Control Board
9	Wire Between Control Board and Switch
10	Wire Between Control Board to Connector (2x Red, 2x Black)

Note:

Bottom view with #43 31-06-0011 Subbase Assembly removed.



SERVICE PARTS EXPLODED VIEW - continued

FIG.	PART NO.	DESCRIPTION OF PART	QTY.
1	-----	Transfer Bit	(1)
2	-----	Plastic Coupler	(1)
3	-----	C-Ring	(1)
4	-----	Offset Base Housing w/ Nameplate Label	(1)
10	-----	M6 x 14mm M Screw	(1)
17	42-70-0068	Rubber Belt	(1)
18	-----	Offset Base Plate	(1)
19	-----	M4 x .7 FH M Screw	(4)
20	-----	M4 x .7 Hex Nut	(1)
21	-----	Base Bracket	(1)
22	-----	Adjustment Bracket	(1)
23	-----	E-Ring	(2)
24	-----	Rivet Pin	(2)
25	-----	M4 x .7mm M 3mm Hex Bolt	(1)
26	-----	Base Locking Lever	(1)
27	43-44-0043	1/4" Collet	(1)
28	48-68-0031	Collet Nut	(1)
30	12-25-0338	Nameplate Label (Not Shown)	(1)
40	49-96-0032	3mm Allen Key	(1)
41	14-70-0011	Latching Kit	(1)
42	14-46-0151	Transfer Bit Assembly	(1)
43	31-06-0011	Subbase Assembly	(1)
50	48-10-5602	Offset Base Assembly	(1)

LUBRICATION INSTRUCTIONS

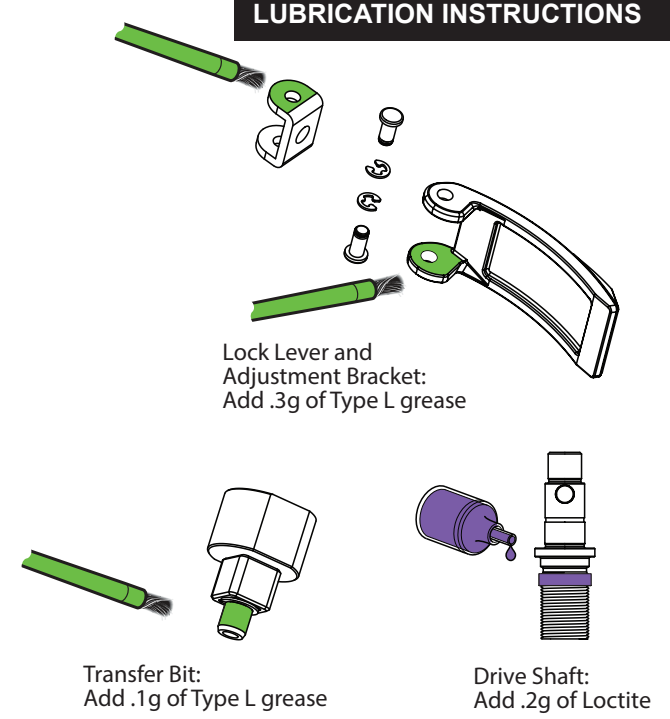

Lock Lever and Adjustment Bracket:
Add .3g of Type L grease

Transfer Bit:
Add .1g of Type L grease

Drive Shaft:
Add .2g of Loctite

SERVICE PARTS EXPLODED VIEW - continued

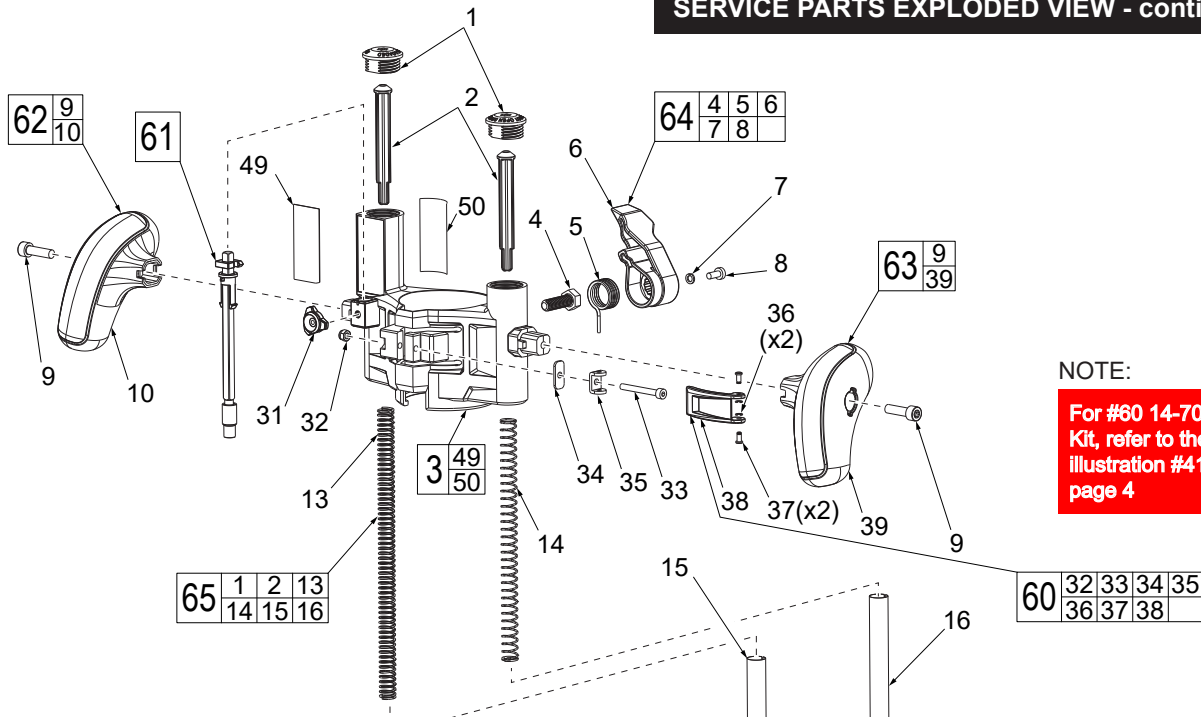

NOTE:
For #60 14-70-0011 Latching Kit, refer to the Latching Kit illustration #41 14-70-0011 on page 4

FIG.	PART NO.	DESCRIPTION OF PART	QTY.
1	-----	Plastic Spring Cap	(2)
2	-----	Plastic Spring Guide	(2)
3	-----	Plunge Base Carrier w/ Nameplate and Scale	(1)
4	05-74-0052	M8 x 1.25" Brass M Screw	(1)
5	-----	Torsion Spring	(1)
6	-----	Lock Lever	(1)
7	-----	Spring Washer	(1)
8	05-74-0053	M4 x 10mm T-25 PH Screw	(1)
9	05-74-0015	M6 x 21.5mm T-30 M Screw	(2)
10	-----	Left Handle	(1)
13	-----	Long Compression Spring	(1)
14	-----	Short Compression Spring	(1)
15	-----	Long Clear Plastic Tube	(1)
16	-----	Short Clear Plastic Tube	(1)
17	-----	Long Plunge Rail	(1)
18	-----	Short Plunge Rail	(1)
19	-----	Die Cast Plunge Base	(1)
20	-----	Plunge Base Plate	(1)

FIG.	PART NO.	DESCRIPTION OF PART	QTY.
21	05-74-0054	M4 x 10mm PH Screw	(4)
22	-----	DepthTurret	(1)
23	-----	Spring and Cover Assembly	(1)
24	-----	Curved Washer	(2)
25	05-74-0057	M4 x 10mm T-25 M Screw	(1)
31	43-98-0057	Plastic Threaded Knob	(3)
32	-----	M4 x .7 Hex Nut	(1)
33	-----	M4 x .7 3mm Hex Bolt	(1)
34	-----	Lock Lever Wear Plate	(1)
35	-----	Locking Yoke	(1)
36	-----	E-Ring	(2)
37	-----	3mm Rivet Pin	(2)
38	-----	Locking Lever	(1)
39	-----	Right Handle	(1)
40	-----	Dust Port Bracket	(1)
41	-----	Dust Port	(1)
49	-----	Scale Label	(1)
50	12-25-0337	Nameplate Label	(1)
60	14-70-0011	Latching Kit	(1)
61	44-94-0026	Depth Rod Assembly w/ Square Rod	(1)
62	31-44-0217	Left Handle Kit	(1)
63	31-44-0222	Right Handle Kit	(1)
64	44-10-0056	Lock Lever Kit	(1)
65	40-50-0163	Spring Kit	(1)
66	49-90-0025	Dust Extraction Kit	(1)
67	14-46-0153	Turret Kit	(1)
68	28-28-0041	Subbase Plate Kit	(1)
69	43-98-0116	Edge Guide Kit	(1)
70	48-10-5601	Plunge Base Assembly	(1)

LUBRICATION INSTRUCTIONS

