



SERVICE PARTS LIST

BULLETIN NO.
54-06-2163

SPECIFY CATALOG NO. AND SERIAL NO. WHEN ORDERING PARTS		REVISED BULLETIN	DATE
REDLITHIUM™ USB Hard Hat Headlamp			Feb. 2022
CATALOG NO.	2163-20	STARTING SERIAL NO.	N14A
WIRING INSTRUCTION			

EXAMPLE:

00	0
----	---

 Component Parts (Small #)
 Are Included When Ordering
 The Assembly (Large #).

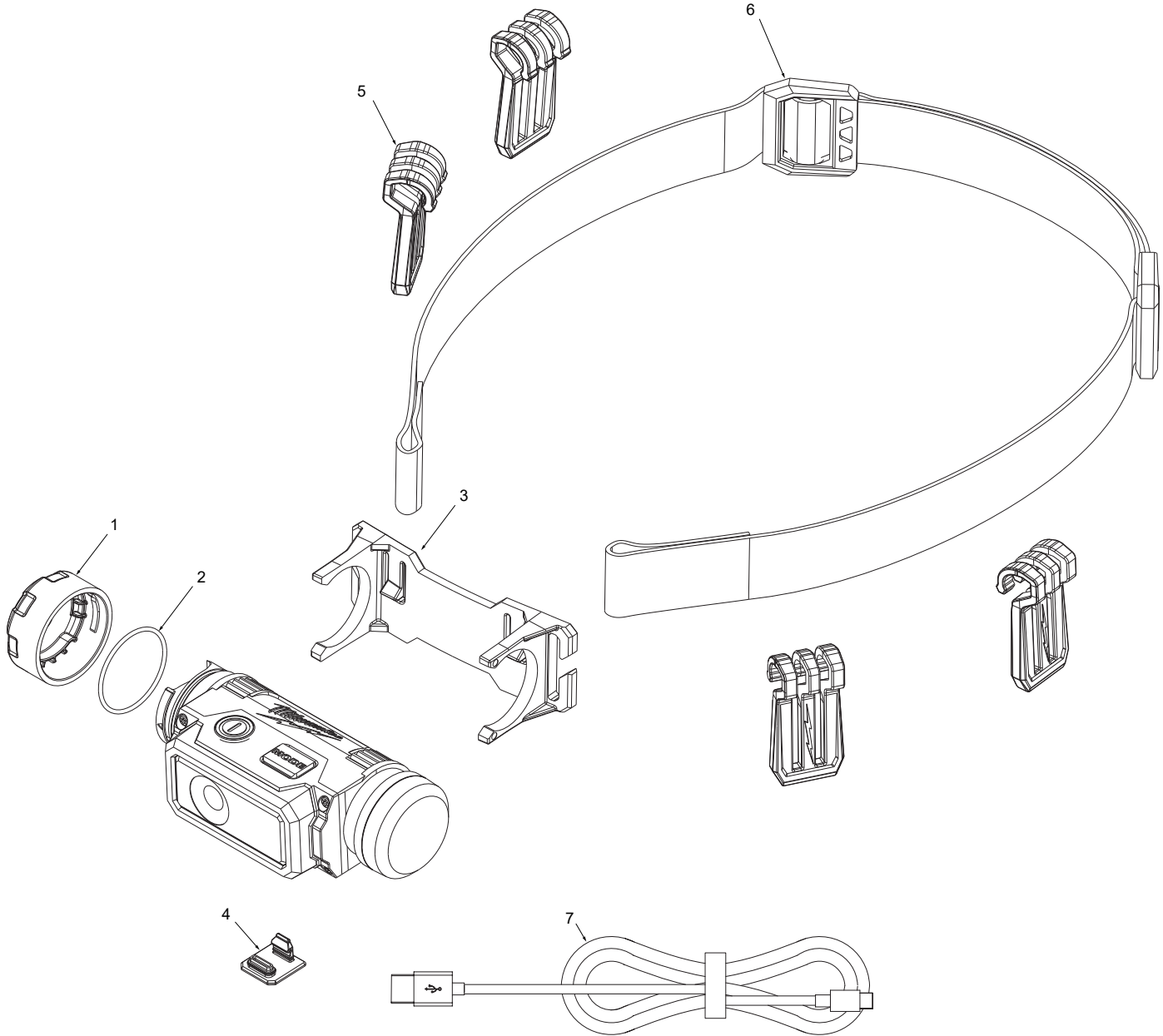

FIG.	PART NO.	DESCRIPTION OF PART	NO. REQ.
1	31-12-0106	Cap	(1)
2	34-40-0219	O-Ring	(1)
3	43-75-2163	Bracket w/ Pad	(1)
4	31-15-2118	Rubber USB Cover	(1)
5	42-70-2103	Light Band Clip Kit (Set of 4)	(1)
6	45-56-2163	Strap	(1)
7	42-44-1210	2' USB-C Cable (Optional)	(1)
8	48-11-2131	REDLITHIUM® USB Battery (Optional)	(1)
9	12-20-2163	Service Nameplate (Not Shown)	(1)

FIG. NOTES

9 A clean, dry surface is essential for proper performance for any adhesive system. The area intended for application of any adhesive label or nameplate must be prepared by cleaning with isopropyl alcohol. The solvent is to be applied with a clean, lint free applicator and the surface allowed to dry before applying the label or nameplate.