



MODEL 116RC

Linear Track Motion System

APPLICATIONS: Provides guidance, support, movement or positioning for heavy panels, boards, components, used in medical apparatus, machinery and manufacturing equipment. Also, the 116RC can be fitted for heavy-duty sliding door applications requiring low pull force.

MODEL 116RC

Linear Track Motion System
Aluminum Track
Re-circulating ball carriages
Up to 1,300 lbs. [600 kg]

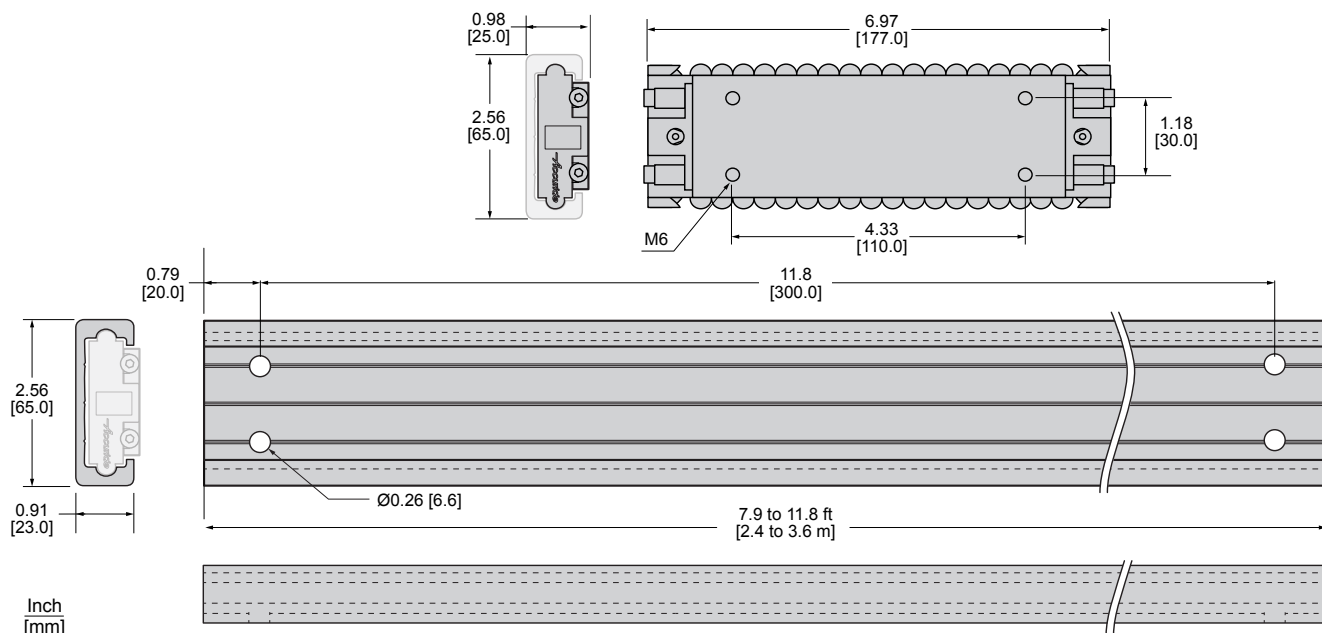

Track Material	Aluminum 6000 series	Load rating	1,300 lbs. [600 kg]*
Track Lengths	94.50" [2.4 m] & 141.73" [3.6 m]	Mounting	Side, flat, or vertical*
Ball Carriages	Stainless Steel and nylon	Hardware	M6 flat head screws ¼" Flat head screws (Not included)
Ball bearing	Stainless Steel or polymer		

* Vertical mounting should be used only for non-load bearing applications.

Load Rating

The load bearing capacity is based on the type and number of carriages. Due to the extensive variety of applications and possible orientations, we recommend that customers test this product to their specific requirements. This product is not recommended for high-torque applications.

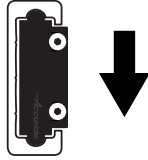
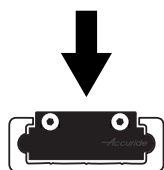
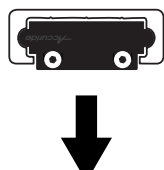
	Side Mount			
	SS116-CASSRC Stainless Steel Ball Carriage	Load Rating lbs [kg]	CB116-CASSRC Polymer Ball Carriage	Load Rating lbs [kg]
	X1	550 [250]	X1	330 [150]
	X2	1,100 [350]	X2	660 [300]
	X3	1,320 [600]	X3	792 [360]
	Flat Mount (carriage up)			
	SS116-CASSRC Stainless Steel Ball Carriage	Load Rating lbs [kg]	CB116-CASSRC Polymer Ball Carriage	Load Rating lbs [kg]
	X1	440 [200]	X1	292 [133]
	X2	880 [400]	X2	585 [266]
	X3	1,056 [480]	X3	701 [319]
	Flat Mount (carriages down)			
	SS116-CASSRC Stainless Steel Ball Carriage	Load Rating lbs [kg]	CB116-CASSRC Polymer Ball Carriage	Load Rating lbs [kg]
	X1	550 [250]	X1	330 [150]
	X2	1,100 [500]	X2	660 [300]
	X3	1,320 [600]	X3	792 [360]

Weight should be evenly distributed across the carriage(s).

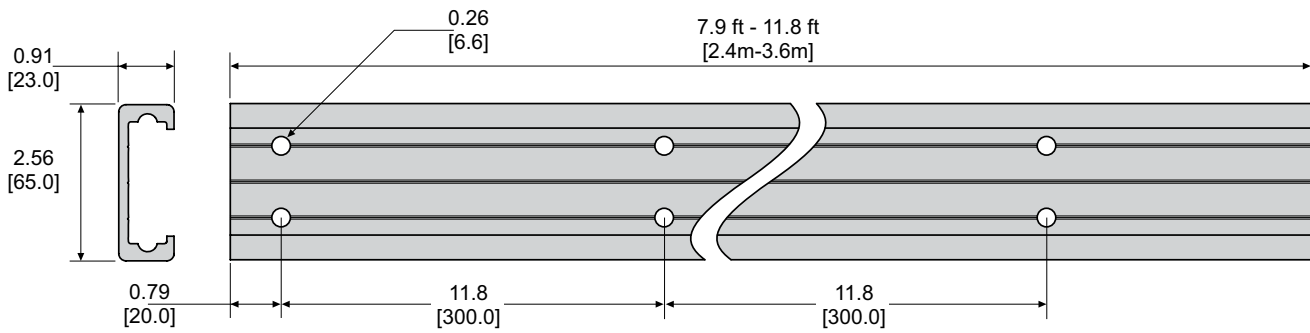

Preparing the Track

1. Select the appropriate length of aluminum track.
2. Calculate the length of track required, keeping in mind the following measurements: each stop is 0.63" [15.9 mm] wide, each carriage 5.7" [177 mm] long (compressed), and each Damper is 7.28" [145 mm] long.
3. Cut track to the determined length. Multiple lengths of track may be butted together for a longer span.
4. Using the two guidelines measure along the length of the track and drill countersunk fixing holes as required. Each hole should be fully countersunk 11.81" [300 mm] apart.
5. For end stops use the back of the track and measure .79" [20 mm] in from each end of the track and drill countersunk holes .26" [06.6 mm] in diameter. Two holes per end, four holes total.
6. Clean the track of any particles and proceed to the assembly stage
7. Fix one end stop to one end of the track using two screws. Leave the other end of the track open to feed carriages. When all carriages are placed on the track, install the second end stop to close the track.



Installing Carriages

8. Align the outer plastic sheath of the carriage to the aluminum track and butt the end of the plastic sheath against the end of the track.
9. Slide the carriage from the plastic sheath into the aluminum track.

! Ensure the plastic sheath is fully pressed against the aluminum track before sliding the carriage through; otherwise, the unit will fall out and drop ball bearings. Use flat and even surface for the action to avoid misalignment.

10. Repeat until all carriages are installed within the confines of the track.

11. Install the other end stop using two screws mount slide as desired on a clean and flat surface.

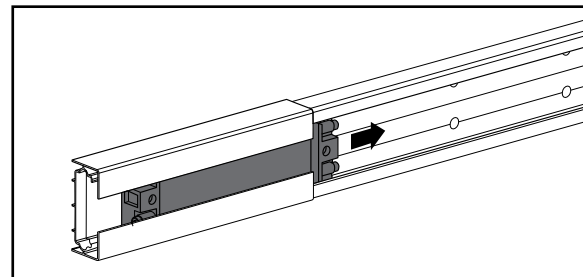
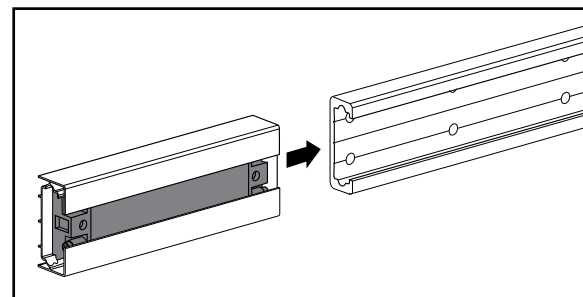

The optional Damper (CB0116-DAMP) cushions and decelerates the last 1.6" [40 mm] of travel. End stops are not required if Damper is used. However a recycling bracket (SS0166-BRKT01RC) must be use to protect the carriages, order as many brackets as carriages. If Damper is used on sliding door applications a door bracket kit must be used instead.

To install the Damper measure .79" [20 mm] from the end of the track and then secure to the track with M6.

! Damper must be use with recycling bracket or with door mounting kit.

Optional Sliding Door Mounting Hardware

Description	Part Number
Support Beam 142" [3.6m] (x1)	AL0116-SUPPRC
Fascia 142" [3.6m] (x1)	AL0116-FASCRC
Fascia end caps (2 caps + 8 screws)	AL0116-ECAPRC-2
Door Bracket kit	SS0116-BRKT-KIT

CB0116-DAMP

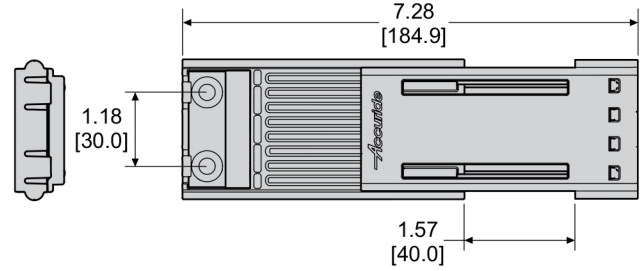

SS0166-BRKT01RC

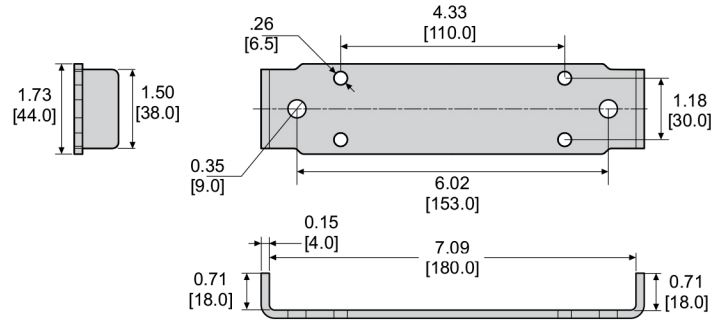

SS0116-BRKT-KIT

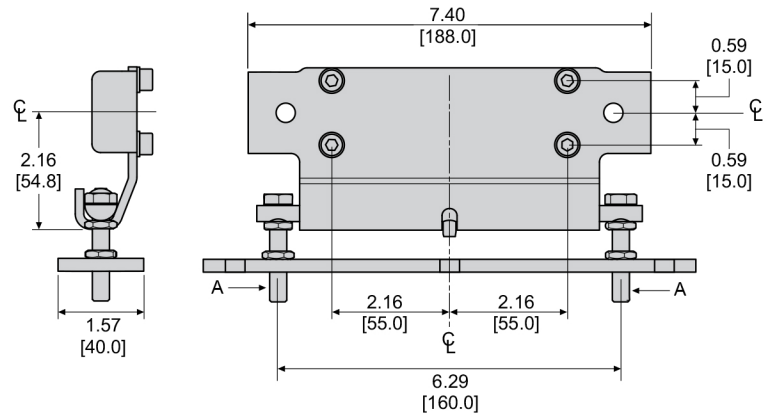

Note A: 3/8 [9.5] x 1.0 [25] clearance holes required for height adjustment bolts.

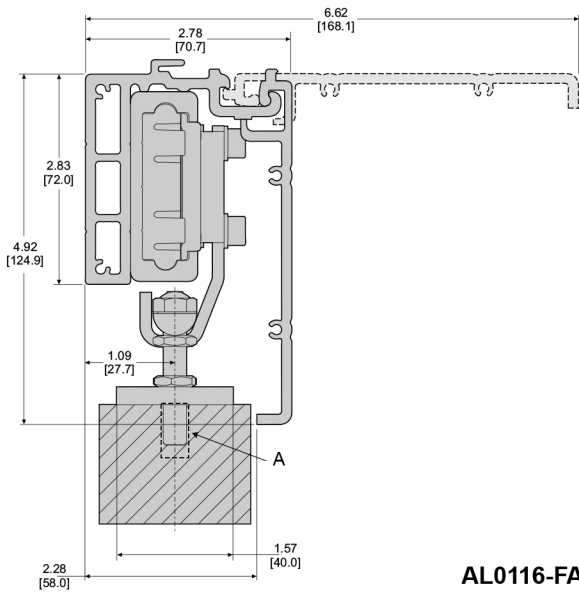

AL0116-ECAPRC-2

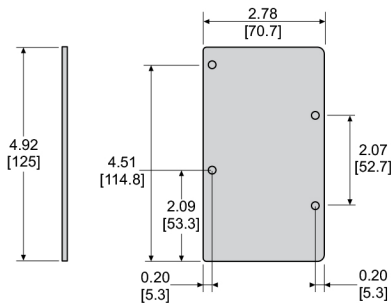

AL0116-FASCRC

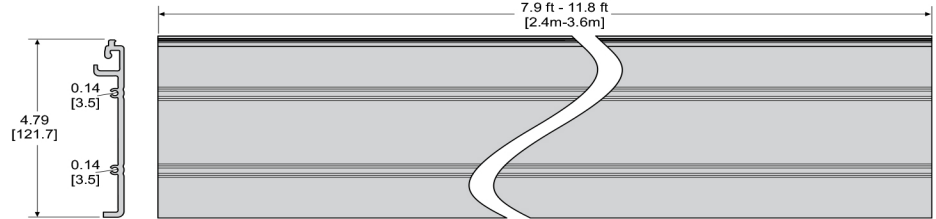

AL0116-SUPPRC

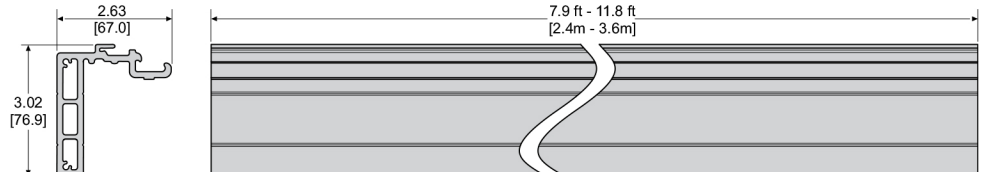

Follow the steps described on page 2 for 116RC track installation, except on step 4 when drilling the fixing holes to the track you also need to drill matching holes to the supporting wall and the supporting beam. The support beam offsets the track for doors up to 2.25" [58 mm] thick. Then attach both pieces to the wall using 1/4" flat head screws. (Figures 1 and 2)

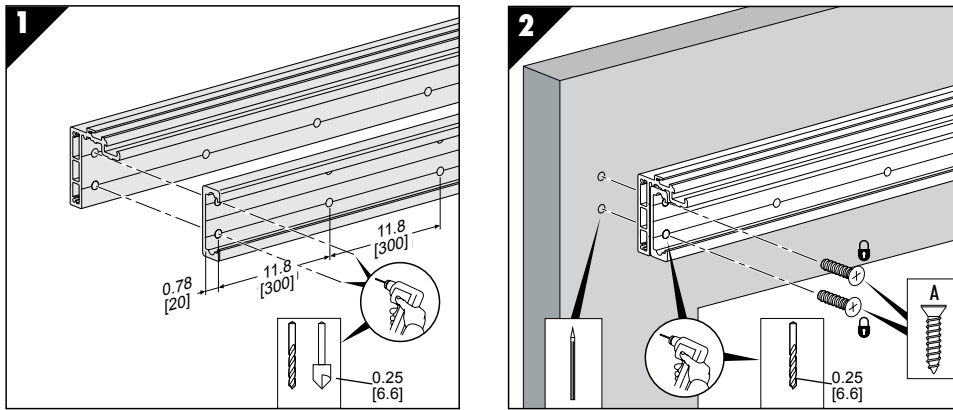

Then proceed to feed the carriages to the track needed for your application. (Figures 3a, 3b, and 3c)

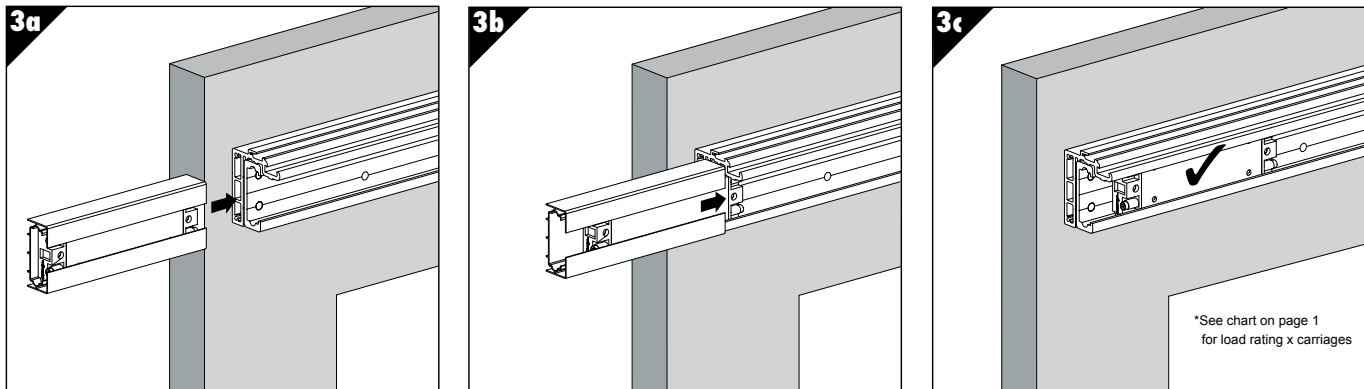

Next, either install the optional Damper (Figures 4a, 4b, and 4c), or the end stops.

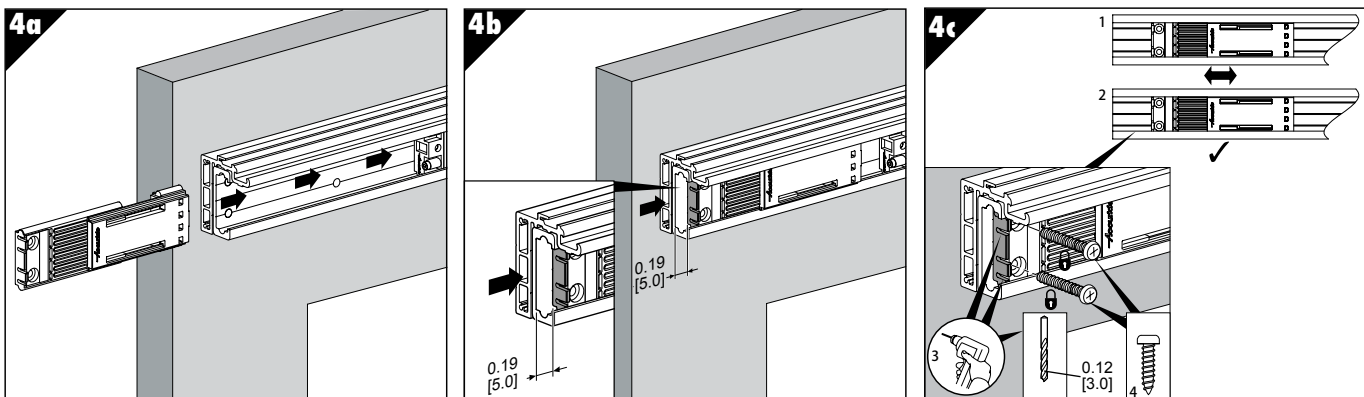

Mount the hardware kit on the door using M8 screws, then hang the door by attaching the top of the hardware kit to the carriages using additional M8 screws. (Figures 5, 6, and 7)

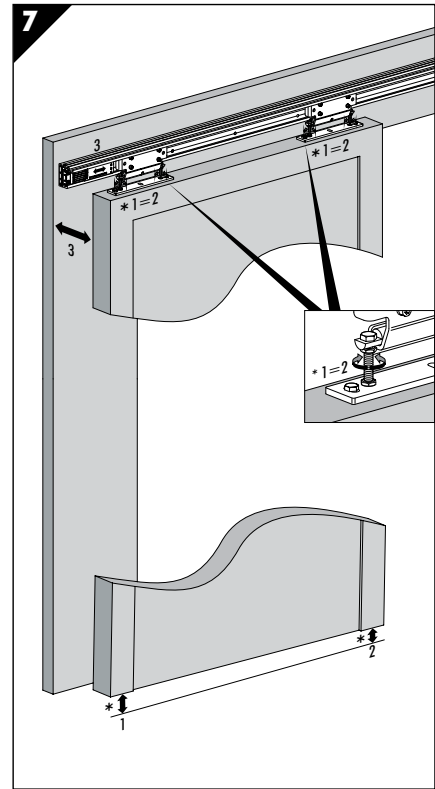
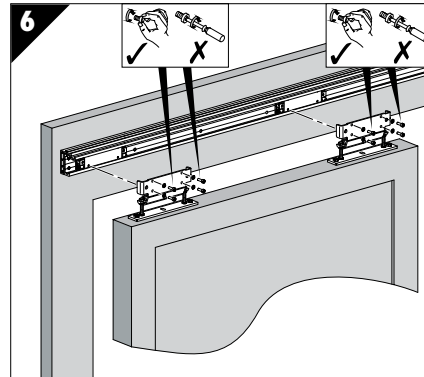
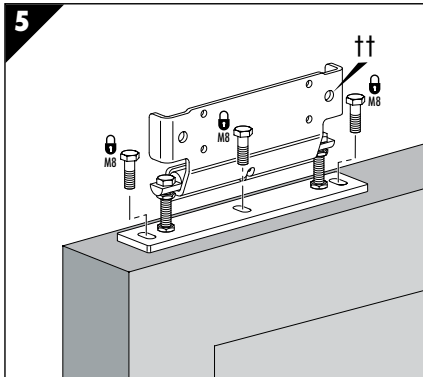

Install the fascia by aligning it to the support beam. Lower the fascia before installing the end caps. (Figures 8, 9a, and 9b)

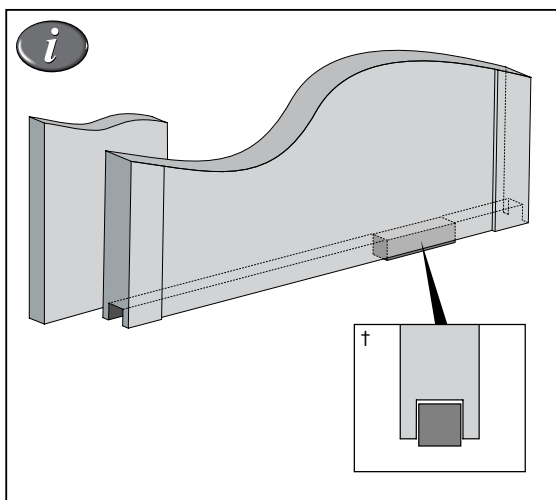
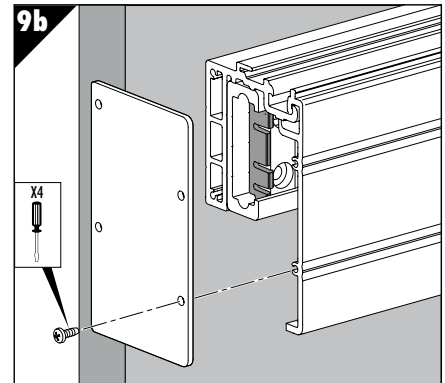
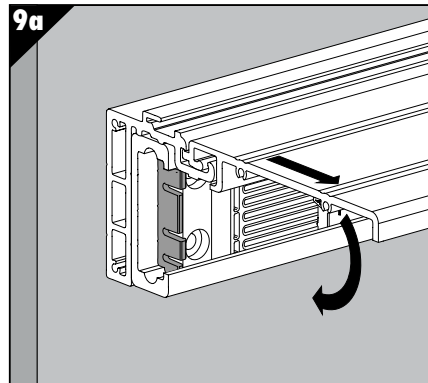
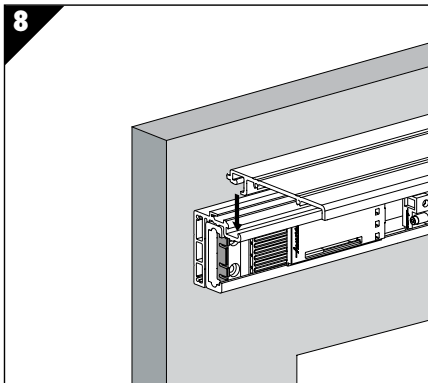

- Note:**
- Customer must supply floor guide.
 - If Damper is not used, protections buffers will be needed at the top and bottom of door/frame.
 - Lubrication: Castrol Spherol Grease to NLGI 2 or similar. Apply through hole in carriage/bracket using a conical grease nozzle.

Packaging & Ordering

Components are sold singly or as a kit, review part numbers and descriptions below.

Components

AL0116-0240RC	94.50" [2.4 m] Aluminum track (x1)
AL0116-0360RC	141.73" [3.6 m] Aluminum track (x1)
SS0116-CASSRC	Carriage - Stainless steel balls (x1)
CB0116-CASSRC	Carriage - Polymer balls (x1)
AL0116-STOPRC	End stops (2 stops + 2 Screws)
SS0166-BRKT01RC	Recycling bracket

Optional Kits

CB0116-DAMP	Damper (x1)
--------------------	-------------

Door Hardware

AL0116-SUPPRC	Support beam (x1)
AL0116-FASCRC	Fascia (x1)
AL0116-ECAPRC-2	Fascia end caps (x1)
SS0116-BRKT-KIT	Door Bracket kit

116RC ordering example

Complete your order for model 116RC by specifying the following:

	QTY	P/N	Length
Total Tracks	4 ea	AL0116	0240RC
	QTY	Carriage type	
Total Carriages	8 ea	SS0116-CASS RC	
	QTY	P/N	
Damper	8 ea	DP0116-DAMP	
Recycling Bracket	8 ea	SS0166-BRKT01RC	

Accuride

ACCURIDE INTERNATIONAL INC.

12311 Shoemaker Avenue
Santa Fe Springs, CA 90670
TEL (562) 903-0200
FAX (562) 903-0208
www accuride.com

Manufacturing, Engineering, and Sales

United States • Germany • Japan • Mexico • United Kingdom • China

Copyright © 2023 Accuride International Inc. TE_116RC_R2_3M_0223_ALA